

インサート軸受

INSERT BEARINGS

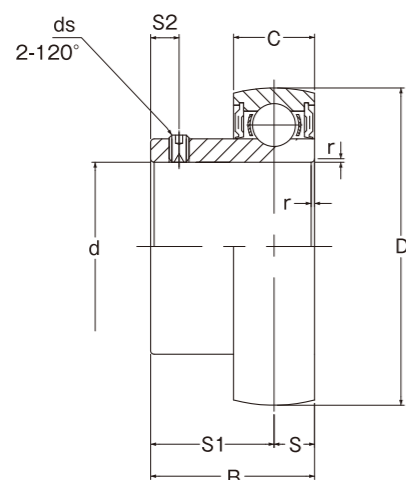

標準仕様

Standard Specification

軸受 Bearing	K形	SUJ2(相当) (equivalent)
	S K形	SUS440C(相当) (equivalent)
潤滑油 Lubricant	K形	リチウム系グリース Lithium Greases
	S K形	H1 認証食品用グリース H1 Certificated Grease For Food
耐熱温度 Heat-Resistant Temperature	K形	110℃(参考値)
	S K形	120℃(参考値)

RoHS 10

軽量形ベアリングユニット用(止めねじタイプ)〈K形〉

LIGHT BEARING UNITS (Set Screw Type) (K)

軸径 Shaft Dia (mm)	型番 Number	主要寸法(mm) Main Dimensions (mm)									基本定格荷重 Basic Load Rating		重量 (kg) Weight (Kg) Reference
		d	D	B	C	r	S	S1	S2	ds	Cr(N)	Cor(N)	
10	K000	10	26	14	8	0.7	4	10	3	M3×0.35	4600	1960	0.02
12	K001	12	28	14.5	8	0.7	4	10.5	3	M3×0.35	5090	2400	0.03
15	K002	15	32	16.5	9	0.7	4.5	12	3.5	M4×0.5	5580	2840	0.04
17	K003	17	35	17.5	10	0.8	5	12.5	3.5	M4×0.5	5970	3280	0.05
20	K004	20	42	21	12	1.3	6	15	4	M5×0.5	9350	5040	0.08
25	K005	25	47	22.5	12	1.3	6	16.5	4.5	M5×0.5	10100	5600	0.10
30	K006	30	55	24.5	13	1.5	6.5	18	5.0	M5×0.5	13200	8000	0.15

軽量形ステンレスベアリングユニット用(止めねじタイプ)〈SK形〉

STAINLESS LIGHT BEARING UNITS (Set Screw Type) (SK)

軸径 Shaft Dia (mm)	型番 Number	主要寸法(mm) Main Dimensions (mm)									基本定格荷重 Basic Load Rating		重量 (kg) Weight (Kg) Reference
		d	D	B	C	r	S	S1	S2	ds	Cr(N)	Cor(N)	
10	SK000	10	26	14	8	0.7	4	10	3	M3×0.5	4600	1960	0.02
12	SK001	12	28	14.5	8	0.7	4	10.5	3	M3×0.5	5090	2400	0.03
15	SK002	15	32	16.5	9	0.7	4.5	12	3.5	M4×0.7	5580	2840	0.04
17	SK003	17	35	17.5	10	0.8	5	12.5	3.5	M4×0.7	5970	3280	0.05
20	SK004	20	42	21	12	1.3	6	15	4	M5×0.8	9350	5040	0.08
25	SK005	25	47	22.5	12	1.3	6	16.5	4.5	M5×0.8	10100	5600	0.10
30	SK006	30	55	24.5	13	1.5	6.5	18	5.0	M5×0.8	13200	8000	0.15

Cr=基本動定格荷重 Cor=基本静定格荷重
Cr=Basic dynamic rated load Cor=Basic static rated load

コンパクトベアリングユニット

COMPACT BEARING UNITS

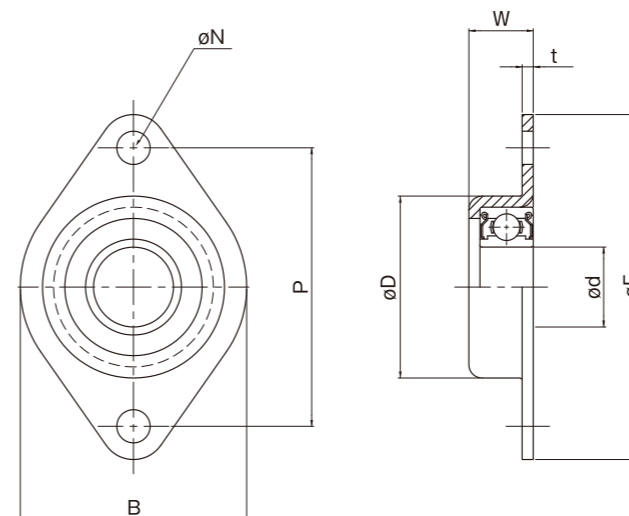

標準仕様

Standard Specification

軸受 Bearing	スチール Steel	SUJ2(相当) (equivalent)
	ステンレス Stainless	SUS440C(相当) (equivalent)
ハウジング Housing	スチール Steel	SPCC(相当)四三酸化鉄皮膜 (equivalent) Alkaline Blackening
	ステンレス Stainless	SUS304(相当) (equivalent)
潤滑油 Lubricant	スチール Steel	リチウム系グリース Lithium Greases
	ステンレス Stainless	リチウム系グリース Lithium Greases
耐熱温度 Heat-Resistant Temperature	スチール Steel	110℃(参考値)
	ステンレス Stainless	120℃(参考値)

RoHS 10

スチールタイプ

STEEL TYPE

軸径 Shaft Dia	型番 Unit Number	使用軸受 Use Bearing	主要寸法(mm) Main Dimensions (mm)							重量 (kg) Weight (Kg) Reference
			B	t	W	P	F	D	N	
8	CU-608	608ZZ	32	1.2	8.2	34	42	24.4	4.5	0.02
10	CU-6000	6000ZZ	36	1.2	9.2	38	46	28.4	4.5	0.03
10	CU-6200	6200ZZ	40	1.2	10.2	42	50	32.4	4.5	0.04
12	CU-6201	6201ZZ	45	1.4	11.4	48	58	34.8	5.5	0.06
15	CU-6002	6002ZZ	45	1.4	11.4	48	58	34.8	5.5	0.06

ステンレスタイプ

STAINLESS TYPE

軸径 Shaft Dia	型番 Unit Number	使用軸受 Use Bearing	主要寸法(mm) Main Dimensions (mm)							重量 (kg) Weight (Kg) Reference
			B	t	W	P	F	D	N	
8	SSCU-608	SS608ZZ	32	1.0	8.0	34	42	24.0	4.5	0.02
10	SSCU-6000	SS6000ZZ	36	1.0	9.0	38	46	28.0	4.5	0.03
10	SSCU-6200	SS6200ZZ	40	1.0	10.0	42	50	32.0	4.5	0.04
12	SSCU-6201	SS6201ZZ	45	1.4	11.4	48	58	34.8	5.5	0.06
15	SSCU-6002	SS6002ZZ	45	1.4	11.4	48	58	34.8	5.5	0.06

Cr=基本動定格荷重 Cor=基本静定格荷重
Cr=Basic dynamic rated load Cor=Basic static rated load