

信頼のブランド

KMT
CORPORATION®

CATALOG

It is a KMT corporation that we send to you.

日本KMT

株式会社 **KMT**

大阪府東大阪市長田東5-2-24
TEL 06-6746-3123 FAX 06-6746-8691
URL <https://www.e-kmt.com>

中国KMT

紹興上虞凱明特貿易有限公司

中国浙江省紹興市上虞区崧厦鎮共何村西洋湖工業区
TEL 0086-575-82937510 FAX 0086-575-82937310
URL <https://www.e-kmt.com>

本カタログに記載の写真、記事、デザイン等の無断転載、複製、転用を禁じます。
Copy of the photos and articles in this catalog is forbidden.

品質管理とブランドは日本

Quality control and Brand are from Japan

信頼のブランド

KMT
CORPORATION®

CONTENTS



品質への取り組み Action To Quality	3-4
ベアリング Bearings	5-12
ステンレス ベアリング Stainless Bearings	13-18
セラミックベアリング Ceramic Bearings	19-22
ベアリングユニット Bearing Units	23-26
ステンレス ベアリングユニット Stainless Bearing Units	27-30
軽量形ベアリングユニット Light Bearing Units	31-34
軽量形ステンレス ベアリングユニット Light Stainless Bearing Units	35-38
インサート軸受 Insert Bearings	39
ステンレスベアリングユニット用カバー Stainless Bearing Units Cover	40
インサート軸受(軽量型) Insert Bearings (Light)	41-42
コンパクトベアリングユニット Compact Bearing Units	43
止めねじ付きベアリング Ball Bearings Set Screw Type	44
オイルレスブッシュ(オイルレスベアリング) Oilless Bushes (Oilless Bearings)	45-46
技術資料 Technical Data	47-54
付表	55-61
ミニチュア/小径玉軸受型番対照表	55
ベアリングユニット型番対照表	56
はめあい寸法公差	57-60
はめあい方式の選択	61

徹底した品質管理の下、「低価格」「短納期」「高品質」の製品をお届けします。

We offer products with shorter delivery term, lower price, but higher quality to our customers through our quality control system.

KMTでは、ベアリング・ベアリングユニットなどの製品をKMTブランドとして販売しております。

We have our own KMT Brand bearings, bearing units for sell.

製品を経済的、効率的に生産し、確かな「品質」をお届けするために、社内検査と第三者機関による検査を行っております。

KMTブランド製品は、材料成分・寸法精度・回転精度ともにJISに準拠しており、日本製品と同等の品質を追求しております。

We inspect our products ourselves and also have an examination run by a third party that make sure our produce process economically and effectively. So that we can control the quality of our products. From Material, Dimensions, to Rotating accuracy, KMT products are all made according to the JIS standards. Because we pursue the same quality as Japanese products.

JIS基準を満たす品質の実現 Realization of the Quality Under JIS Standard

最適な工場選定

Optimal reliable factory selection

使用材料はJIS相当

JIS standard compliant material

JISに準じた精度基準

JIS compliant accuracy standard

日本製潤滑グリスを封入

Enclosed Japan-made lubricating grease

KMTブランド製品は、材料成分・寸法回転精度ともにJISに準拠しており、日本製品と同等の品質を追求しております。

From Material composition to Dimensions / Rotation accuracy, KMT products are all made according to the JIS standards. We pursue the same excellent quality as Japan manufactured products.

品質管理体制 Quality Control System

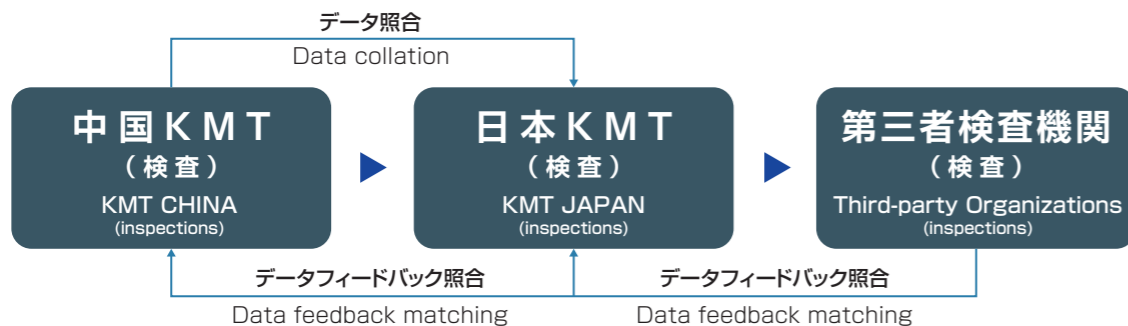

中国KMTと日本KMT、さらに第三者検査機関で振動検査から寸法回転精度検査、外観検査を徹底して行っております。

KMT CHINA and JAPAN, as well as third-party organizations, thoroughly carry out vibration inspections, dimensional rotation accuracy inspections, and visual inspections.

日本のお客様だけでなく、海外のお客様にも同じ品質でご提供

We can provide the same high quality products for the customers in both Japan and overseas.

確かな「品質」をお届けするために TO DELIVER RELIABLE QUALITY

中国KMTと日本KMT、さらに第三者検査機関でも検査を行っており、日本のお客様にも、海外のお客様にも同じ品質でご提供します。

Our products are tested by KMT JAPAN, KMT CHINA, and a third party. So that we can provide the same quality products for customers in Japan or overseas.

中国KMT

KMT CHINA

品質管理体制

寸法・回転精度はJIS Z9015-1に準じた抜取検査、振動・外観は全数検査を実施

Quality Control System

Sampling inspection is performed for dimensions and rotation accuracy according to JIS Z9015-1 standard. Also, 100% inspection for vibration and appearances.

日本KMT

KMT JAPAN

品質管理体制

社内規定に準じた抜取検査を実施
中国KMTの検査データを照合

Quality Control System

Conducted sampling inspection in accordance with company regulations. Collate inspection data of China KMT.

第三者検査機関

THE THIRD PARTY

品質管理体制

日本軸受検査協会(JBI)にて、客観的検査を実施
全型番適宜依頼(一部対応不可項目有り)

Quality Control System

We perform objective inspections appropriately, conducted by JBI(Japan Bearing Inspection), for all bearing model numbers.(some items cannot be supported.)

社内検査 INTERNAL INSPECTION

振動検査 (デシベル検査、アンデロン検査)

ベアリングの回転時に生じる振動を検出することで、真円度、内外輪軌道面の面粗度、鋼球・保持器の欠陥や異物混入の検出など、総合的な品質判断を行っております。(ベアリングのみ)



Vibration Examination

An examination to get vibration data when bearings are rotating. We analysis the data to find the problems on [Roundness], [Roughness], [cages], then make a judgment about the quality.

寸法精度検査・回転精度検査

JISに定められた方法で、主要寸法の検査を行っております。また、継続的に許容範囲内の製品をお届けするため、統計的品質管理手法を用いて、品質のバラツキの検証を行っております。



Dimension & Rotation Examination

We check the dimension according to the JIS Standard. To deliver products following the tolerance, we have our own quality control system to control the unevenness among the products.

外観検査

見た目の仕上がりも含めた製品提供を追求し、「キズ」「錆び」「へこみ」などの検査を行っております。ベアリングでは、目視レベル基準を明確に数値化し、検査レベルの均一化を図るため、自動外観検査装置を導入しております。

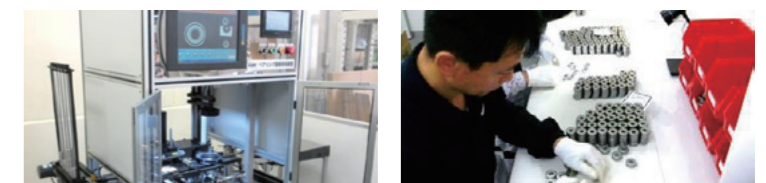

Appearance Inspection

Product Appearance is also considered as an important subject. We inspect the products with [Scratch], [Rustiness], [Dent] and so on. We use Automatic Appearance Inspection Equipment to make sure the Appearance Inspection standard can be controlled.

社外検査 EXTERNAL INSPECTION

第三者検査機関での検査

日本軸受検査協会…ベアリングの寸法精度・回転精度検査を依頼
日鉄テクノロジー…材料成分・ミクロ組織・硬度試験などを依頼
中国ベアリング協会の国家機関…材料成分・ミクロ組織・硬度・耐久試験などを依頼

Examination run by Third Party

JBI : Examination on Dimension & Rotation of the bearings
Nittetsu technology : Examination on Micro Observation, Heat Treatment, Hardness.
State Organization Of Chinese KMT Association : Examination on Micro Observation, Heat Treatment, Hardness.

※中国KMTは中国ベアリング協会の会員です。 ※CBIA : Examination on Micro Observation, Heat Treatment, Hardness.

相対評価試験 (要請時)

お客様のご使用されているメーカーとKMT製を同条件で寿命試験にかけ、試験前後の寸法精度・回転精度や振動値の比較測定を行います。また、試験後に分解し、軌道面の摩耗状態など総合的な検証を行います。



Comparing Test (requested only)

We do a comparing test between the bearing that customer's using and a KMT bearing. We will compare the data from the test on [Dimension], [Rotation Examination], [Vibration] and so on. After the test, we disassemble the test object to check the abrasion and make a judgement on the bearing.

ベアリング

BEARINGS



ミニチュア / 小径玉軸受

MINIATURE/SMALL BALL BEARINGS

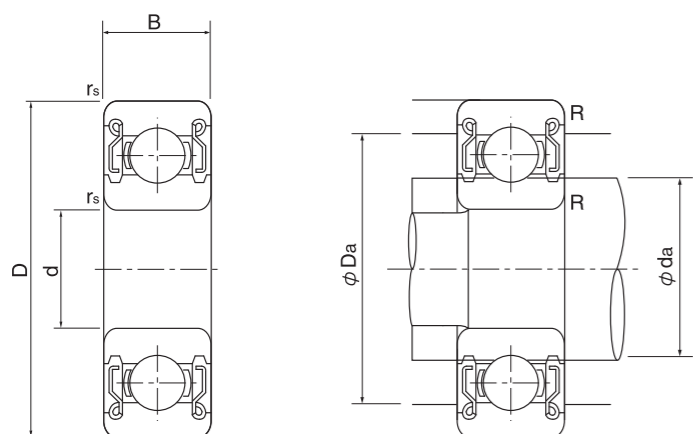

標準仕様

Standard Specification

内外輪 Inner and Outer Rings	SUJ2(相当) (equivalent)
ボール Ball	SUJ2(相当) (equivalent)
保持器 Cage	SPCC/SUS304(相当) (equivalent)
シールド Shields	SPCC/SUS304(相当) (equivalent)
シール Seals	SPCC(相当)+ニトリルゴム SPCC(equivalent)+Nitrile Rubber
潤滑油 Lubricant	リチウム系グリース Lithium Greases
精度等級 Accuracy Class	JIS 0級 JIS 0 Class
すきま Clearance	MC3 MC3 Clearance
耐熱温度 Heat-Resistant Temperature	Z Z 110°C(参考値) 2RS 100°C(参考値) 2RZ 110°C(参考値)

RoHS 10

主要寸法(mm) Main Dimensions(mm)				型番 Bearing Number			基本定格荷重 Basic Load Rating		取付関係寸法(mm)参考値 Installation Dimension(mm) Reference Value			許容回転数(rpm) Allowable Maximum Speed(rpm)		重量(g) 参考 Weight(g) Reference
d	D	B	rs (min)	シールド形 Shields	接触シール形 Contact Rubber Seal	非接触シール形 Non-Contact Rubber Seal	Cr (N)	Cor (N)	Da (min)	da (max)	R (max)	ZZ-2RZ	2RS	
3	6	2.5	0.05	MR63ZZ	—	—	208	74	5.4	3.7	0.10	71000	—	0.27
	7	3	0.10	683ZZ	—	—	310	110	6.4	4.0	0.10	63000	—	0.45
	8	3	0.10	MR83ZZ	—	—	395	139	7.3	4.0	0.10	60000	—	0.64
	8	4	0.15	693ZZ	—	—	560	179	7.3	4.3	0.15	60000	—	0.83
	9	4	0.15	MR93ZZ	—	—	570	187	7.9	4.3	0.15	56000	—	1.18
	9	5	0.15	603ZZ	—	—	570	187	7.9	4.3	0.15	56000	—	1.45
	10	4	0.15	623ZZ	—	—	630	218	8.0	4.3	0.15	50000	—	1.66
	4	7	2.5	0.10	MR74ZZ	—	—	255	107	6.3	4.8	0.10	60000	—
8		3	0.05	MR84ZZ	—	—	395	139	7.4	5.0	0.10	56000	—	0.56
9		4	0.10	684ZZ	—	—	640	225	8.1	5.2	0.10	53000	—	1.01
10		4	0.15	MR104ZZ	—	—	710	270	8.8	5.9	0.20	50000	—	1.42
11		4	0.15	694ZZ	—	—	960	345	9.9	5.6	0.20	48000	—	1.75
12		4	0.20	604ZZ	—	—	960	345	9.9	5.6	0.20	48000	—	2.29
13		5	0.20	624ZZ	—	—	1300	485	11.3	6.0	0.20	40000	—	3.04
16		5	0.30	634ZZ	—	—	1730	670	13.8	7.5	0.30	36000	—	5.21

Cr=基本動定格荷重 Cor=基本静定格荷重

Cr=Basic dynamic rated load Cor=Basic static rated load

※上記型番以外も製造可能です。お気軽にお問い合わせください。

※We can also produce bearings not in the list. Please contact us.

主要寸法(mm) Main Dimensions(mm)				型番 Bearing Number			基本定格荷重 Basic Load Rating		取付関係寸法(mm)参考値 Installation Dimension(mm) Reference Value			許容回転数(rpm) Allowable Maximum Speed(rpm)		重量(g) 参考 Weight(g) Reference
d	D	B	rs (min)	シールド形 Shields	接触シール形 Contact Rubber Seal	非接触シール形 Non-Contact Rubber Seal	Cr (N)	Cor (N)	Da (min)	da (max)	R (max)	ZZ-2RZ	2RS	
5	8	2.5	0.05	MR85ZZ	—	—	310	120	7.4	5.8	0.10	53000	—	0.34
	9	3	0.15	MR95ZZ	—	—	430	168	8.2	6.0	0.15	50000	—	0.58
	10	4	0.10	MR105ZZ	—	—	430	168	8.4	6.0	0.20	50000	—	1.29
	11	4	0.10	MR115ZZ	—	—	715	276	9.8	6.3	0.15	48000	—	1.49
	11	5	0.15	685ZZ	—	—	715	281	9.9	6.2	0.15	45000	—	1.96
	13	4	0.10	695ZZ	2RS	2RZ	1080	430	11.2	6.6	0.20	43000	40000	2.50
	14	5	0.20	605ZZ	2RS	2RZ	1330	505	12.2	6.9	0.20	40000	38000	3.48
	16	5	0.20	625ZZ	2RS	2RZ	1730	670	13.8	7.5	0.30	36000	32000	4.86
6	19	6	0.30	635ZZ	2RS	2RZ	2340	885	16.5	8.5	0.30	32000	30000	8.34
	10	3	0.10	MR106ZZ	—	—	495	218	9.3	7.0	0.15	45000	—	0.68
	12	4	0.10	MR126ZZ	—	—	715	292	10.9	7.2	0.20	43000	—	1.74
	13	5	0.15	686ZZ	2RS	2RZ	1080	440	11.7	7.4	0.20	40000	38000	2.69
	15	5	0.20	696ZZ	2RS	2RZ	1730	670	13.3	7.9	0.30	40000	38000	3.72
	17	6	0.30	606ZZ	2RS	2RZ	2260	835	14.8	8.2	0.30	38000	34000	6.08
	19	6	0.30	626ZZ	2RS	2RZ	2340	885	16.5	8.5	0.30	32000	30000	7.94
	22	7	0.30	636ZZ	2RS	2RZ	3300	1370	19.0	10.5	0.30	30000	28000	14.00
7	11	3	0.10	MR117ZZ	—	—	455	201	10.5	8.0	0.10	43000	—	0.72
	13	4	0.15	MR137ZZ	—	—	540	276	11.6	9.0	0.15	40000	—	2.02
	14	5	0.15	687ZZ	2RS	2RZ	1170	510	12.7	8.5	0.15	40000	34000	2.97
	17	5	0.30	697ZZ	2RS	2RZ	1610	710	14.8	10.2	0.30	36000	28000	5.12
	19	6	0.30	607ZZ	2RS	2RZ	2340	885	16.5	9.1	0.30	36000	32000	7.51
	22	7	0.30	627ZZ	2RS	2RZ	3300	1370	19.0	10.5	0.30	30000	28000	12.90
8	12	3.5	0.10	MR128ZZ	—	—	545	274	11.3	9.0	0.15	40000	—	0.97
	14	4	0.15	MR148ZZ	—	—	820	385	12.8	9.2	0.20	38000	—	2.16
	16	5	0.20	688ZZ	2RS	2RZ	1610	710	14.2	10.2	0.20	36000	28000	4.02
	19	6	0.30	698ZZ	2RS	2RZ	2240	910	16.5	10.0	0.30	36000	28000	7.18
	22	7	0.30	608ZZ	2RS	2RZ	3300	1370	19.0	10.5	0.30	34000	28000	12.20
	24	8	0.30	628ZZ	2RS	2RZ	3350	1430	20.5	12.0	0.30	28000	24000	17.40
9	28	9	0.30	638ZZ	2RS	2RZ	4550	1970	22.8	12.8	0.30	28000	22000	28.60
	17	5	0.20	689ZZ	2RS	2RZ	1330	665	15.2	11.5	0.20	36000	24000	4.43
	20	6	0.30	699ZZ	2RS	2RZ	1720	840	17.2	12.0	0.30	34000	24000	8.33
	24	7	0.30	609ZZ	2RS	2RZ	3350	1430	20.5	12.0	0.30	32000	24000	14.70
	26	8	0.30	629ZZ	2RS	2RZ	4550	1970	22.8	12.8	0.30	28000	22000	19.30

Cr=基本動定格荷重 Cor=基本静定格荷重

Cr=Basic dynamic rated load Cor=Basic static rated load

※上記型番以外も製造可能です。お気軽にお問い合わせください。

※We can also produce bearings not in the list. Please contact us.

※接触シール形(2RS)の接触量は各社異なります。

※Different companies have differences on the quantity of contact seal (2RS).

ベアリング

BEARINGS



ミニチュア/小径玉軸受(フランジ付き)

MINIATURE/SMALL BALL BEARINGS (WITH FLANGED OUTER RING)

標準仕様 Standard Specification

- 内外輪 Inner and Outer Rings SUJ2(相当) (equivalent)
- ボール Ball SUJ2(相当) (equivalent)
- 保持器 Cage SPCC/SUS304(相当) (equivalent)
- シールド Shields SPCC/SUS304(相当) (equivalent)
- シール Seals SPCC(相当)+ニトリルゴム SPCC(equivalent)+Nitrile Rubber
- 潤滑油 Lubricant リチウム系グリース Lithium Greases
- 精度等級 Accuracy Class JIS 0級 JIS 0 Class
- すきま Clearance MC3 MC3 Clearance
- 耐熱温度 Heat-Resistant Temperature Z Z 110°C(参考値)
2RS 100°C(参考値)
2RZ 110°C(参考値)

RoHS 10

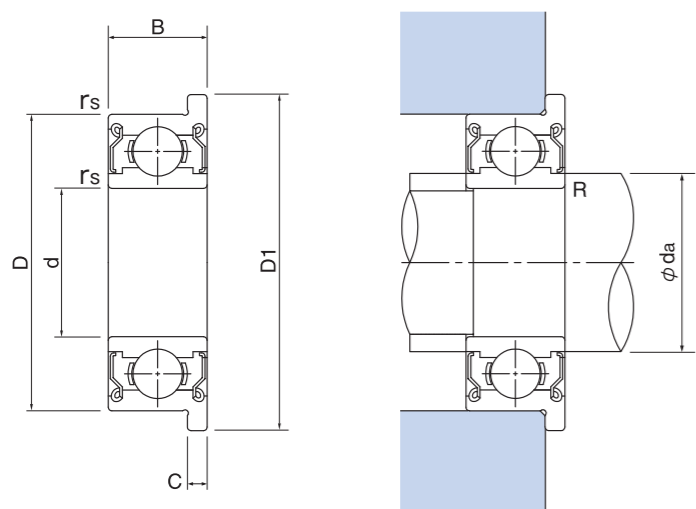

主要寸法(mm) Main Dimensions(mm)						型番 Bearing Number			基本定格荷重 Basic Load Rating		取付関係寸法(mm)参考値 Installation Dimension(mm) Reference Value		許容回転数(rpm) Allowable Maximum Speed(rpm)		重量(g) 参考 Weight(g) Reference
d	D	D1	B	C	r _s (min)	シールド形 Shields	接触シール形 Contact Rubber Seal	非接触シール形 Non-Contact Rubber Seal	Cr (N)	Cor (N)	da (max)	R (max)	ZZ-2RZ	2RS	
3	6	7.2	2.5	0.6	0.10	MF63ZZ	—	—	208	74	3.7	0.10	71000	—	0.33
	7	8.1	3	0.8	0.10	F683ZZ	—	—	310	110	4.0	0.10	63000	—	0.53
	8	9.2	3	0.6	0.10	MF83ZZ	—	—	395	139	4.0	0.10	60000	—	0.73
	8	9.5	4	0.9	0.15	F693ZZ	—	—	560	179	4.3	0.15	60000	—	0.97
	9	10.6	4	0.8	0.15	MF93ZZ	—	—	570	187	4.3	0.15	56000	—	1.34
	9	10.5	5	1.0	0.15	F603ZZ	—	—	570	187	4.3	0.15	56000	—	1.63
4	10	11.5	4	1.0	0.15	F623ZZ	—	—	630	218	4.3	0.15	50000	—	1.86
	7	8.2	2.5	0.6	0.10	MF74ZZ	—	—	255	107	4.8	0.10	60000	—	0.35
	8	9.2	3	0.6	0.05	MF84ZZ	—	—	395	139	5.0	0.10	56000	—	0.63
	9	10.3	4	1.0	0.10	F684ZZ	—	—	640	225	5.2	0.10	53000	—	1.14
	10	11.6	4	0.8	0.15	MF104ZZ	—	—	710	270	5.9	0.20	50000	—	1.59
	11	12.5	4	1.0	0.15	F694ZZ	—	—	960	345	5.6	0.20	48000	—	1.96
4	12	13.5	4	1.0	0.20	F604ZZ	—	—	960	345	5.6	0.20	48000	—	2.53
	13	15.0	5	1.0	0.20	F624ZZ	—	—	1300	485	6.0	0.20	40000	—	3.53

Cr=基本動定格荷重 Cor=基本静定格荷重

Cr=Basic dynamic rated load Cor=Basic static rated load

※上記型番以外も製造可能です。お気軽にお問い合わせください。

※We can also produce bearings not in the list. Please contact us.

主要寸法(mm) Main Dimensions(mm)						型番 Bearing Number			基本定格荷重 Basic Load Rating		取付関係寸法(mm)参考値 Installation Dimension(mm) Reference Value		許容回転数(rpm) Allowable Maximum Speed(rpm)		重量(g) 参考 Weight(g) Reference
d	D	D1	B	C	r _s (min)	シールド形 Shields	接触シール形 Contact Rubber Seal	非接触シール形 Non-Contact Rubber Seal	Cr (N)	Cor (N)	da (max)	R (max)	ZZ-2RZ	2RS	
5	8	9.2	2.5	0.6	0.05	MF85ZZ	—	—	310	120	5.8	0.10	53000	—	0.41
	9	10.2	3	0.6	0.15	MF95ZZ	—	—	430	168	6.0	0.15	50000	—	0.66
	10	11.6	4	0.8	0.10	MF105ZZ	—	—	430	168	6.0	0.20	50000	—	1.46
	11	12.6	4	1.0	0.15	MF115ZZ	—	—	715	276	6.3	0.15	48000	—	1.67
	11	12.5	5	1.0	0.15	F685ZZ	—	—	715	281	6.2	0.15	45000	—	2.18
	13	15.0	4	1.0	0.20	F695ZZ	2RS	2RZ	1080	430	6.6	0.20	43000	40000	2.84
6	14	16.0	5	1.0	0.20	F605ZZ	2RS	2RZ	1330	505	6.9	0.20	40000	38000	3.85
	10	11.2	3	0.6	0.10	MF106ZZ	—	—	495	218	7.0	0.15	45000	—	0.77
	12	13.6	4	0.8	0.15	MF126ZZ	—	—	715	292	7.2	0.20	43000	—	1.94
	13	15.0	5	1.1	0.15	F686ZZ	2RS	2RZ	1080	440	7.4	0.20	40000	38000	3.04
7	15	17.0	5	1.2	0.20	F696ZZ	2RS	2RZ	1730	670	7.9	0.30	40000	38000	4.26
	17	19.0	6	1.2	0.30	F606ZZ	2RS	2RZ	2260	835	8.2	0.30	38000	34000	6.61
	14	16.0	5	1.1	0.20	F687ZZ	2RS	2RZ	1170	510	8.5	0.15	40000	34000	3.37
8	17	19.0	5	1.2	0.30	F697ZZ	2RS	2RZ	1610	710	10.2	0.30	36000	28000	5.65
	19	22.0	6	1.5	0.30	F607ZZ	2RS	2RZ	2340	885	9.1	0.30	36000	32000	8.66
	12	13.6	3.5	0.8	0.15	MF128ZZ	—	—	545	274	9.0	0.15	40000	—	1.15
9	14	15.6	4	0.8	0.15	MF148ZZ	—	—	820	385	9.2	0.20	38000	—	2.39
	16	18.0	5	1.1	0.20	F688ZZ	2RS	2RZ	1610	710	10.2	0.20	36000	28000	4.47
	19	22.0	6	1.5	0.30	F698ZZ	2RS	2RZ	2240	910	10.0	0.30	36000	28000	8.30
	22	25.0	7	1.5	0.30	F608ZZ	2RS	2RZ	3300	1370	10.5	0.30	34000	28000	13.50
9	17	19.0	5	1.1	0.20	F689ZZ	2RS	2RZ	1330	665	11.5	0.20	36000	24000	4.91
	20	23.0	6	1.5	0.30	F699ZZ	2RS	2RZ	1720	840	12.0	0.30	34000	24000	9.51
	24	27.0	7	1.5	0.30	F609ZZ	2RS	2RZ	3350	1430	12.0	0.30	32000	24000	16.00

Cr=基本動定格荷重 Cor=基本静定格荷重

Cr=Basic dynamic rated load Cor=Basic static rated load

※上記型番以外も製造可能です。お気軽にお問い合わせください。

※We can also produce bearings not in the list. Please contact us.

※接触シール形(2RS)の接触量は各社異なります。

※Different companies have differences on the quantity of contact seal (2RS).

ベアリング

BEARINGS



深溝玉軸受

DEEP GROOVE BALL BEARINGS

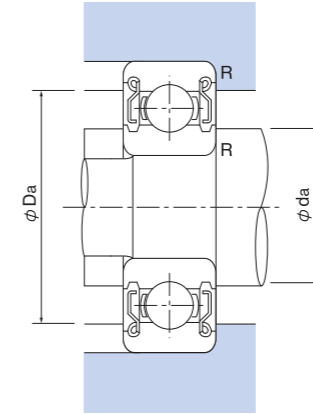
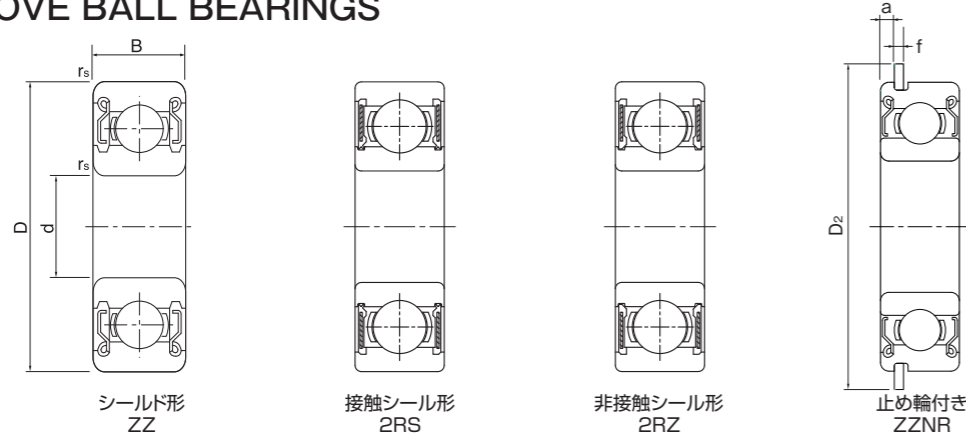

RoHS 10

標準仕様 Standard Specification

内外輪 Inner and Outer Rings	SUJ2(相当) (equivalent)
ボール Ball	SUJ2(相当) (equivalent)
保持器 Cage	SPCC/SUS302/SUS304(相当) (equivalent)
シールド Shields	SPCC(相当) (equivalent)
シール Seals	SPCC(相当)+ニトリルゴム SPCC(equivalent)+Nitrile Rubber
潤滑油 Lubricant	リチウム系グリース Lithium Greases
精度等級 Accuracy Class	JIS 0級 JIS 0 Class
すきま Clearance	CN/C3 CN Clearance
耐熱温度 Heat-Resistant Temperature	Z Z 110°C(参考値) 2RS 100°C(参考値) 2RZ 110°C(参考値)

主要寸法(mm) Main Dimensions(mm)				型番 Bearing Number				止め輪寸法 Dimensions with the snap ring		
d	D	B	rs (min)	シールド形 Shields	接触シール形 Contact Rubber Seal	非接触シール形 Non-Contact Rubber Seal	止め輪付き With snap ring	a (参考値)	D ₂ (参考値)	f (参考値)
10	15	4	0.3	6700ZZ	2RS	2RZ	—	—	—	—
	19	5	0.3	6800ZZ	2RS	2RZ	—	—	—	—
	22	6	0.3	6900ZZ	2RS	2RZ	ZZNR	1.05	24.8	0.70
	26	8	0.3	6000ZZ	2RS	2RZ	ZZNR	1.73	29.2	0.70
	30	9	0.6	6200ZZ	2RS	2RZ	ZZNR	2.06	34.7	1.12
	35	11	0.6	6300ZZ	2RS	2RZ	ZZNR	2.06	39.7	1.12
12	18	4	0.3	6701ZZ	2RS	2RZ	—	—	—	—
	21	5	0.3	6801ZZ	2RS	2RZ	—	—	—	—
	24	6	0.3	6901ZZ	2RS	2RZ	ZZNR	1.05	26.8	0.70
	28	8	0.3	6001ZZ	2RS	2RZ	ZZNR	1.35	30.8	0.85
	32	10	0.6	6201ZZ	2RS	2RZ	ZZNR	2.06	36.7	1.12
	37	12	1.0	6301ZZ	2RS	2RZ	ZZNR	2.06	41.3	1.12
15	21	4	0.2	6702ZZ	2RS	2RZ	—	—	—	—
	24	5	0.3	6802ZZ	2RS	2RZ	—	—	—	—
	28	7	0.3	6902ZZ	2RS	2RZ	ZZNR	1.30	30.8	0.85
	32	9	0.3	6002ZZ	2RS	2RZ	ZZNR	2.06	36.7	1.12
	35	11	0.6	6202ZZ	2RS	2RZ	ZZNR	2.06	39.7	1.12
17	42	13	1.0	6302ZZ	2RS	2RZ	ZZNR	2.06	46.3	1.12
	23	4	0.15	6703ZZ	2RS	2RZ	—	—	—	—
	26	5	0.3	6803ZZ	2RS	2RZ	—	—	—	—
	30	7	0.3	6903ZZ	2RS	2RZ	ZZNR	1.30	32.8	0.85
	35	10	0.3	6003ZZ	2RS	2RZ	ZZNR	2.06	39.7	1.12
20	40	12	0.6	6203ZZ	2RS	2RZ	ZZNR	2.06	44.6	1.12
	47	14	1.0	6303ZZ	2RS	2RZ	ZZNR	2.46	52.7	1.12
	27	4	0.1	6704ZZ	2RS	2RZ	—	—	—	—
	32	7	0.3	6804ZZ	2RS	2RZ	ZZNR	1.30	34.8	0.85
	37	9	0.3	6904ZZ	2RS	2RZ	ZZNR	1.70	39.8	0.85
20	42	12	0.6	6004ZZ	2RS	2RZ	ZZNR	2.06	46.3	1.12
	47	14	1.0	6204ZZ	2RS	2RZ	ZZNR	2.46	52.7	1.12
	52	15	1.1	6304ZZ	2RS	2RZ	ZZNR	2.46	57.9	1.12

Cr=基本動定格荷重 Cor=基本静定格荷重
Cr=Basic dynamic rated load Cor=Basic static rated load

※上記型番以外も製造可能です。お気軽にお問い合わせください。
※We can also produce bearings not in the list. Please contact us.
※輪溝寸法と止め輪寸法は、JIS B 1512に準じておりません。
※Snap ring groove dimensions and snap ring dimensions are not conformed to JIS B 1512.

基本定格荷重 Basic Load Rating		取付関係寸法(mm)参考値 Installation Dimension(mm) Reference Value				許容回転数(rpm) Allowable Maximum Speed(rpm)		重量(g) 参考 Weight(g) Reference
Cr(N)	Cor(N)	Da (max)	da (max)	da (min)	R (max)	ZZ-2RZ	2RS	
855	435	13.9	11.5	11.5	0.15	15000	9990	2
1590	760	17.0	12.0	12.0	0.30	34000	24000	5
2690	1270	20.0	12.5	12.0	0.30	32000	22000	9
4750	1960	24.0	13.0	12.0	0.30	30000	22000	18
5100	2390	26.0	16.0	14.0	0.60	24000	18000	32
8200	3500	31.0	16.5	14.0	0.60	22000	17000	52
926	530	16.8	13.8	13.8	0.20	13000	8660	3
1910	1040	19.0	14.0	14.0	0.30	32000	20000	6
2890	1450	22.0	14.5	14.0	0.30	30000	20000	10
5100	2390	26.0	15.5	14.0	0.30	28000	18000	23
6800	3050	28.0	17.0	16.0	0.60	22000	17000	37
9700	4200	32.0	18.0	17.0	1.00	20000	16000	60
937	582	19.7	16.8	16.8	0.20	11000	7330	4
2060	1260	22.0	17.0	17.0	0.30	28000	17000	7
4320	2260	26.0	17.0	17.0	0.30	26000	17000	15
5600	2840	30.0	19.0	17.0	0.30	24000	15000	32
7750	3600	31.0	20.5	19.0	0.60	20000	14000	45
11400	5450	37.0	22.5	20.0	1.00	17000	13000	82
1000	658	21.6	18.8	18.8	0.20	9500	6330	4
2130	1360	24.0	19.0	19.0	0.30	26000	15000	7
4310	2310	28.0	19.5	19.0	0.30	24000	15000	17
6800	3350	33.0	21.5	19.0	0.30	22000	13000	39
9600	4600	36.0	23.5	21.0	0.60	17000	12000	65
13500	6550	42.0	25.5	22.0	1.00	15000	11000	115
1038	725	25.3	22.3	22.3	0.20	8500	5660	6
3470	2240	30.0	22.0	22.0	0.30	22000	13000	17
6390	3590	35.0	24.0	22.0	0.30	19000	12000	37
9400	5050	38.0	25.5	24.0	0.60	18000	11000	70
12800	6650	42.0	26.5	25.0	1.00	15000	11000	106
15900	7900	45.5	28.0	26.5	1.00	14000	10000	144

※接触シール形(2RS)の接触量は各社異なります。
※Different companies have differences on the quantity of contact seal (2RS).

ベアリング

BEARINGS



深溝玉軸受

DEEP GROOVE BALL BEARINGS

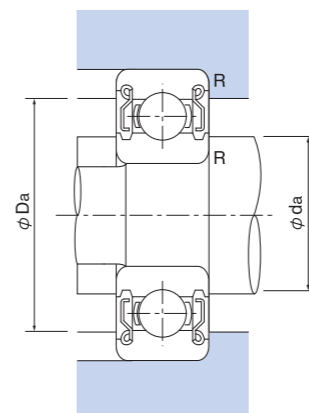
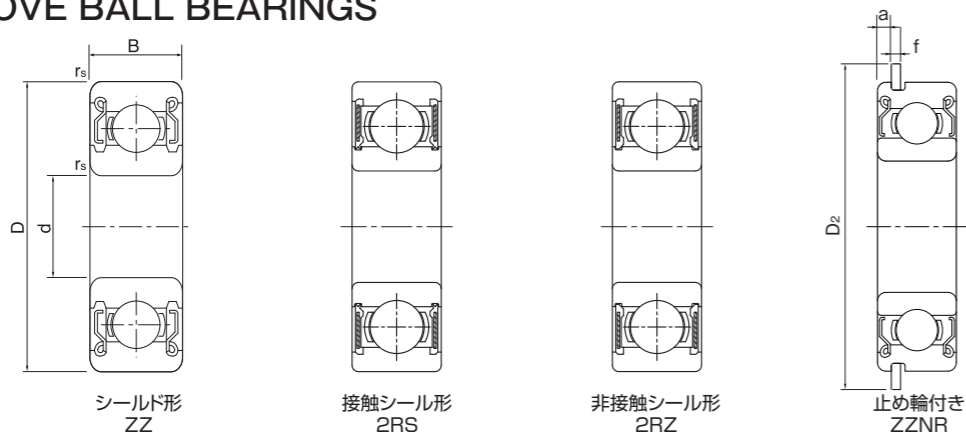

RoHS 10

標準仕様

Standard Specification

内外輪 Inner and Outer Rings	SUJ2(相当) (equivalent)
ボール Ball	SUJ2(相当) (equivalent)
保持器 Cage	SPCC/SUS302/SUS304(相当) (equivalent)
シールド Shields	SPCC(相当) (equivalent)
シール Seals	SPCC(相当)+ニトリルゴム SPCC(equivalent)+Nitrile Rubber
潤滑油 Lubricant	リチウム系グリース Lithium Greases
精度等級 Accuracy Class	JIS 0級 JIS 0 Class
すきま Clearance	CN/C3 CN Clearance
耐熱温度 Heat-Resistant Temperature	Z Z 110°C(参考値) 2RS 100°C(参考値) 2RZ 110°C(参考値)

主要寸法(mm) Main Dimensions(mm)				型番 Bearing Number				止め輪寸法 Dimensions with the snap ring		
d	D	B	r _s (min)	シールド形 Shields	接触シール形 Contact Rubber Seal	非接触シール形 Non-Contact Rubber Seal	止め輪付き With snap ring	a (参考値)	D ₂ (参考値)	f (参考値)
25	37	7	0.3	6805ZZ	2RS	2RZ	ZZNR	1.30	39.8	0.85
	42	9	0.3	6905ZZ	2RS	2RZ	ZZNR	1.70	44.8	0.85
	47	12	0.6	6005ZZ	2RS	2RZ	ZZNR	2.06	52.7	1.12
	52	15	1.0	6205ZZ	2RS	2RZ	ZZNR	2.46	57.9	1.12
	62	17	1.1	6305ZZ	2RS	2RZ	ZZNR	3.28	67.7	1.70
30	42	7	0.3	6806ZZ	2RS	2RZ	ZZNR	1.30	44.8	0.85
	47	9	0.3	6906ZZ	2RS	2RZ	ZZNR	1.70	49.8	0.85
	55	13	1.0	6006ZZ	2RS	2RZ	ZZNR	2.08	60.7	1.12
	62	16	1.0	6206ZZ	2RS	2RZ	ZZNR	3.28	67.7	1.70
	72	19	1.1	6306ZZ	2RS	2RZ	ZZNR	3.28	78.6	1.70
35	47	7	0.3	6807ZZ	2RS	2RZ	ZZNR	1.30	49.8	0.85
	55	10	0.6	6907ZZ	2RS	2RZ	ZZNR	1.70	57.8	0.85
	62	14	1.0	6007ZZ	2RS	2RZ	ZZNR	2.08	67.7	1.70
	72	17	1.1	6207ZZ	2RS	2RZ	ZZNR	3.28	78.6	1.70
40	80	21	1.5	6307ZZ	2RS	2RZ	ZZNR	3.28	86.6	1.70
	52	7	0.3	6808ZZ	2RS	2RZ	ZZNR	1.30	54.8	0.85
	62	12	0.6	6908ZZ	2RS	2RZ	ZZNR	1.70	64.8	0.85
	68	15	1.0	6008ZZ	2RS	2RZ	ZZNR	2.49	74.6	1.70
	80	18	1.1	6208ZZ	2RS	2RZ	ZZNR	3.28	86.6	1.70
45	90	23	1.5	6308ZZ	2RS	2RZ	ZZNR	3.28	96.5	2.46
	58	7	0.3	6809ZZ	2RS	2RZ	ZZNR	1.30	60.8	0.85
	68	12	0.6	6909ZZ	2RS	2RZ	ZZNR	1.70	70.8	0.85
	75	16	1.0	6009ZZ	2RS	2RZ	ZZNR	2.49	81.6	1.70
	85	19	1.1	6209ZZ	2RS	2RZ	ZZNR	3.28	91.6	1.70
50	100	25	1.5	6309ZZ	2RS	2RZ	ZZNR	3.28	106.5	2.46
	65	7	0.3	6810ZZ	2RS	2RZ	ZZNR	1.30	67.8	0.85
	72	12	0.6	6910ZZ	2RS	2RZ	ZZNR	1.70	74.8	0.85
	80	16	1.0	6010ZZ	2RS	2RZ	ZZNR	2.49	86.6	1.70
	90	20	1.1	6210ZZ	2RS	2RZ	ZZNR	3.28	96.5	2.46
110	27	2.0	6310ZZ	2RS	2RZ	ZZNR	3.28	116.6	2.46	

Cr=基本動定格荷重 Cor=基本静定格荷重
Cr=Basic dynamic rated load Cor=Basic static rated load

※上記型番以外も製造可能です。お気軽にお問い合わせください。
※We can also produce bearings not in the list. Please contact us.
※輪溝寸法と止め輪寸法は、JIS B 1512に準じておりません。
※Snap ring groove dimensions and snap ring dimensions are not conformed to JIS B 1512.

基本定格荷重 Basic Load Rating		取付関係寸法(mm)参考値 Installation Dimension(mm) Reference Value				許容回転数(rpm) Allowable Maximum Speed(rpm)		重量(g) 参考 Weight(g) Reference
Cr(N)	Cor(N)	Da (max)	da (max)	da (min)	R (max)	ZZ-2RZ	2RS	
3666	2640	35.0	27.0	27.0	0.30	18000	10000	21
6650	4190	40.0	28.5	28.5	0.30	16000	10000	42
11900	6550	43.0	30.0	30.0	0.60	15000	9500	79
14800	7850	47.0	32.0	32.0	1.00	13000	9000	128
23400	11600	55.5	36.0	36.0	1.00	11000	8000	232
4020	3120	40.0	32.0	32.0	0.30	15000	9000	24
7200	5050	45.0	34.0	32.0	0.30	14000	8500	52
13800	8300	50.0	36.5	35.0	1.00	13000	8000	116
20300	11300	57.0	38.5	35.0	1.00	11000	7500	199
29600	16000	65.5	42.5	36.5	1.00	9500	6700	345
4310	3610	45.0	37.0	37.0	0.30	14000	7500	27
10370	7180	51.0	39.0	39.0	0.60	12000	7500	75
16000	10300	57.0	41.5	40.0	1.00	11000	6700	151
27000	15300	65.5	44.5	41.5	1.00	9500	6300	284
33500	19100	72.0	47.0	43.0	1.50	8500	6000	464
4420	3895	50.0	42.0	42.0	0.30	12000	6700	31
11270	8450	58.0	46.0	44.0	0.60	11000	6300	112
17800	11600	63.0	47.5	45.0	1.00	10000	6000	190
32500	19000	73.5	50.5	46.5	1.00	8500	5600	366
40500	24000	82.0	53.0	48.0	1.50	7500	5300	636
4620	4330	56.0	47.5	47.0	0.30	11000	6000	38
13500	10270	64.0	50.0	49.0	0.60	9500	5600	126
21000	15200	70.0	53.5	50.0	1.00	9000	5300	241
32500	20400	78.5	55.5	51.5	1.00	7500	5300	420
53000	32000	92.0	61.5	53.0	1.50	6700	4800	829
5500	5270	63.0	52.5	52.0	0.60	9500	5300	50
13890	10990	68.0	55.0	54.0	0.60	9000	5300	135
21800	16600	75.0	58.5	55.0	1.00	8500	4800	261
35100	23300	83.5	60.0	56.5	1.00	7100	4800	459
62000	38500	101.0	68.0	59.0	2.00	6000	4300	1060

※接触シール形(2RS)の接触量は各社異なります。
※Different companies have differences on the quantity of contact seal (2RS).

ステンレスベアリング

STAINLESS BEARINGS



ミニチュア / 小径玉軸受

MINIATURE/SMALL BALL BEARINGS

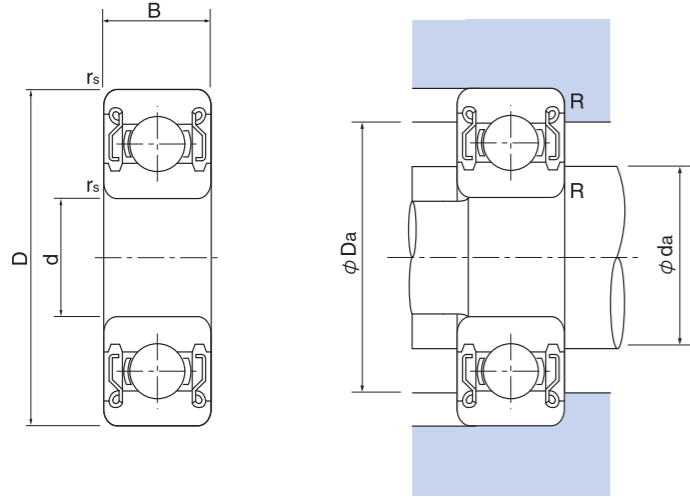

標準仕様

Standard Specification

内外輪 Inner and Outer Rings	SUS440C(相当) (equivalent)
ボール Ball	SUS440C(相当) (equivalent)
保持器 Cage	SUS304(相当) (equivalent)
シールド Shields	SUS304(相当) (equivalent)
シール Seals	SUS304(相当)+ニトリルゴム SUS304(equivalent)+Nitrile Rubber
潤滑油 Lubricant	リチウム系グリース Lithium greases
精度等級 Accuracy Class	JIS 0級 JIS 0 Class
すきま Clearance	MC3 MC3 Clearance
耐熱温度 Heat-Resistant Temperature	Z Z 120°C(参考値) 2RS 100°C(参考値)

RoHS 10

主要寸法(mm) Main Dimensions (mm)				型番 Bearing Number		基本定格荷重 Basic Load Rating		取付関係寸法(mm)参考値 Installation Dimension(mm) Reference Value				許容回転数(rpm) Allowable Maximum Speed(rpm)		重量(g) 参考 Weight(g) Reference
d	D	B	rs (min)	シールド形 Shields	接触シールド形 Contact Seals	Cr(N)	Cor(N)	Da (max)	da (max)	da (min)	R (max)	ZZ	2RS	
3	6	2.5	0.05	SSMR63ZZ	—	208	74	5.4	3.7	—	0.10	61000	—	0.27
	7	3	0.10	SS683ZZ	—	390	130	6.4	4.0	—	0.10	53000	—	0.45
	8	4	0.15	SS693ZZ	2RS	560	179	7.3	4.3	—	0.15	54000	36000	0.83
	9	4	0.15	SSMR93ZZ	2RS	570	187	7.9	4.3	—	0.15	46000	30000	1.18
	9	5	0.15	SS603ZZ	2RS	570	187	7.9	4.3	—	0.15	51000	34000	1.45
	10	4	0.15	SS623ZZ	2RS	630	218	8.0	4.3	—	0.15	45000	30000	1.66
4	7	2.5	0.10	SSMR74ZZ	—	310	115	6.3	4.8	—	0.10	50000	—	0.29
	8	3	0.05	SSMR84ZZ	2RS	395	139	7.4	5.0	—	0.10	46000	30000	0.56
	9	4	0.10	SS684ZZ	2RS	480	170	8.1	5.2	—	0.10	43000	28000	1.01
	10	4	0.15	SSMR104ZZ	2RS	710	270	8.8	5.9	—	0.20	42000	28000	1.42
	11	4	0.15	SS694ZZ	2RS	960	350	9.9	5.6	—	0.20	43000	28000	1.75
	12	4	0.20	SS604ZZ	2RS	960	345	9.9	5.6	—	0.20	48000	32000	2.29
	13	5	0.20	SS624ZZ	2RS	1300	485	11.3	6.0	—	0.20	40000	26000	3.04
	16	5	0.30	SS634ZZ	2RS	1730	670	13.8	7.5	—	0.30	36000	24000	5.21

Cr=基本動定格荷重 Cor=基本静定格荷重

Cr=Basic dynamic rated load Cor=Basic static rated load

※上記型番以外も製造可能です。お気軽にお問い合わせください。

※We can also produce bearings not in the list. Please contact us.

※接触シールド形(2RS)の接触量は各社異なります。

※Different companies have differences on the quantity of contact seal (2RS).

主要寸法(mm) Main Dimensions (mm)				型番 Bearing Number		基本定格荷重 Basic Load Rating		取付関係寸法(mm)参考値 Installation Dimension(mm) Reference Value				許容回転数(rpm) Allowable Maximum Speed(rpm)		重量(g) 参考 Weight(g) Reference
d	D	B	rs (min)	シールド形 Shields	接触シールド形 Contact Seals	Cr(N)	Cor(N)	Da (max)	da (max)	da (min)	R (max)	ZZ	2RS	
5	8	2.5	0.05	SSMR85ZZ	—	310	120	7.4	5.8	—	0.10	43000	—	0.34
	9	3	0.10	SSMR95ZZ	2RS	430	168	8.2	6.0	—	0.15	40000	26000	0.58
	10	4	0.10	SSMR105ZZ	2RS	430	168	8.4	6.0	—	0.20	42000	28000	1.29
	11	4	0.10	SSMR115ZZ	2RS	715	276	9.8	6.3	—	0.15	40000	26000	1.49
	11	5	0.15	SS685ZZ	2RS	770	320	9.9	6.2	—	0.15	43000	40000	1.96
	13	4	0.20	SS695ZZ	2RS	1070	420	11.2	6.6	—	0.20	43000	40000	2.50
	14	5	0.20	SS605ZZ	2RS	1330	505	12.2	6.9	—	0.20	40000	38000	3.48
	16	5	0.30	SS625ZZ	2RS	1730	670	13.8	7.5	—	0.30	36000	32000	4.86
	19	6	0.30	SS635ZZ	2RS	2810	1060	16.5	8.5	—	0.30	32000	30000	8.34
6	10	3	0.05	SSMR106ZZ	2RS	495	218	9.3	7.0	—	0.15	37000	24000	0.68
	12	4	0.20	SSMR126ZZ	2RS	715	292	10.9	7.2	—	0.20	35000	23000	1.74
	13	5	0.15	SS686ZZ	2RS	1080	440	11.7	7.4	—	0.20	40000	38000	2.69
	15	5	0.20	SS696ZZ	2RS	1730	570	13.3	7.9	—	0.30	40000	38000	3.72
	17	6	0.30	SS606ZZ	2RS	2260	835	14.8	8.2	—	0.30	38000	34000	6.08
	19	6	0.30	SS626ZZ	2RS	2340	885	16.5	8.5	—	0.30	32000	30000	7.94
7	11	3	0.15	SSMR117ZZ	2RS	455	201	10.5	8.0	—	0.10	35000	23000	0.72
	13	4	0.20	SSMR137ZZ	2RS	540	276	11.6	9.0	—	0.15	32000	21000	2.02
	14	5	0.15	SS687ZZ	2RS	1170	510	12.7	8.5	—	0.15	35000	23000	2.97
	17	5	0.30	SS697ZZ	2RS	1610	710	14.8	10.2	—	0.30	36000	28000	5.12
	19	6	0.30	SS607ZZ	2RS	2800	1060	16.5	9.1	—	0.30	36000	32000	7.51
8	12	3.5	0.10	SSMR128ZZ	2RS	545	274	11.3	9.0	—	0.15	30000	20000	0.97
	14	4	0.15	SSMR148ZZ	2RS	820	385	12.8	9.2	—	0.20	30000	20000	2.16
	16	5	0.20	SS688ZZ	2RS	1610	710	14.2	10.2	—	0.20	36000	28000	4.02
	19	6	0.30	SS698ZZ	2RS	2240	910	16.5	10.0	—	0.30	36000	28000	7.18
	22	7	0.30	SS608ZZ	2RS	3300	1370	19.0	10.5	—	0.30	34000	28000	12.20
	24	8	0.30	SS628ZZ	2RS	3330	1410	20.5	12.0	—	0.30	28000	24000	17.40
9	28	9	0.30	SS638ZZ	2RS	4550	1970	22.8	12.8	—	0.30	28000	22000	28.60
	17	5	0.20	SS689ZZ	2RS	1330	660	15.2	11.5	—	0.20	36000	24000	4.43
	20	6	0.30	SS699ZZ	2RS	1720	840	17.2	12.0	—	0.30	34000	24000	8.33
	24	7	0.30	SS609ZZ	2RS	3330	1410	20.5	12.0	—	0.30	32000	24000	14.70
26	8	0.30	SS629ZZ	2RS	4160	1780	22.8	12.8	—	0.30	28000	22000	19.30	

Cr=基本動定格荷重 Cor=基本静定格荷重

Cr=Basic dynamic rated load Cor=Basic static rated load

※上記型番以外も製造可能です。お気軽にお問い合わせください。

※We can also produce bearings not in the list. Please contact us.

※接触シールド形(2RS)の接触量は各社異なります。

※Different companies have differences on the quantity of contact seal (2RS).

ステンレスベアリング

STAINLESS BEARINGS

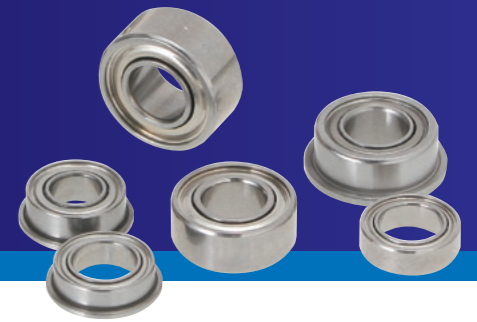

ミニチュア/小径玉軸受(フランジ付き)

MINIATURE/SMALL BALL BEARINGS (WITH FLANGED OUTER RING)

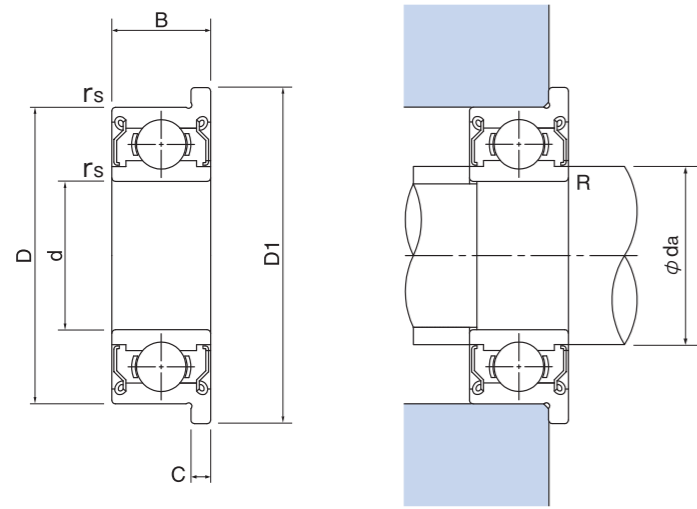

標準仕様

Standard Specification

内外輪 Inner and Outer Rings	SUS440C(相当) (equivalent)
ボール Ball	SUS440C(相当) (equivalent)
保持器 Cage	SUS304(相当) (equivalent)
シールド Shields	SUS304(相当) (equivalent)
シール Seals	SUS304(相当)+ニトリルゴム SUS304(equivalent)+Nitrile Rubber
潤滑油 Lubricant	リチウム系グリース Lithium greases
精度等級 Accuracy Class	JIS 0級 JIS 0 Class
すきま Clearance	MC3 MC3 Clearance
耐熱温度 Heat-Resistant Temperature	Z Z 120°C(参考値) 2RS 100°C(参考値)

RoHS 10

主要寸法(mm) Main Dimensions(mm)						型番 Bearing Number		基本定格荷重 Basic Load Rating		取付関係寸法(mm)参考値 Installation Dimension(mm) Reference Value				許容回転数(rpm) Allowable Maximum Speed(rpm)		重量(g) 参考 Weight(g) Reference
d	D	D1	B	C	r _s (min)	シールド形 Shields	接触シール形 Contact Rubber Seal	Cr (N)	Cor (N)	Da (max)	da (max)	da (min)	R (min)	ZZ	2RS	
3	6	7.2	2.5	0.6	0.10	SSMF63ZZ	—	208	74	5.4	3.7	—	0.10	61000	—	0.33
	7	8.1	3	0.8	0.10	SSF683ZZ	—	390	130	6.4	4.0	—	0.10	53000	—	0.53
	8	9.5	4	0.9	0.15	SSF693ZZ	2RS	560	179	7.3	4.3	—	0.15	54000	36000	0.97
	9	10.6	4	0.8	0.15	SSMF93ZZ	2RS	570	187	7.9	4.3	—	0.15	46000	30000	1.34
	9	10.5	5	1.0	0.15	SSF603ZZ	2RS	570	187	7.9	4.3	—	0.15	51000	34000	1.63
	10	11.5	4	1.0	0.15	SSF623ZZ	2RS	630	218	8.0	4.3	—	0.15	45000	30000	1.86
4	7	8.2	2.5	0.6	0.10	SSMF74ZZ	—	310	115	6.3	4.8	—	0.10	50000	—	0.35
	8	9.2	3	0.6	0.15	SSMF84ZZ	2RS	395	139	7.4	5.0	—	0.10	46000	30000	0.63
	9	10.3	4	1.0	0.15	SSF684ZZ	2RS	480	170	8.1	5.2	—	0.10	43000	28000	1.14
	10	11.6	4	0.8	0.20	SSMF104ZZ	2RS	710	270	8.8	5.9	—	0.20	42000	28000	1.59
	11	12.5	4	1.0	0.20	SSF694ZZ	2RS	960	350	9.9	5.6	—	0.20	43000	28000	1.96
	12	13.5	4	1.0	0.20	SSF604ZZ	2RS	960	345	9.9	5.6	—	0.20	48000	32000	2.53
13	15.0	5	1.0	0.20	SSF624ZZ	2RS	1300	485	11.3	6.0	—	0.20	40000	26000	3.53	

Cr=基本動定格荷重 Cor=基本静定格荷重

Cr=Basic dynamic rated load Cor=Basic static rated load

※上記型番以外も製造可能です。お気軽にお問い合わせください。

※We can also produce bearings not in the list. Please contact us.

※接触シール形(2RS)の接触量は各社異なります。

※Different companies have differences on the quantity of contact seal (2RS).

主要寸法(mm) Main Dimensions(mm)						型番 Bearing Number		基本定格荷重 Basic Load Rating		取付関係寸法(mm)参考値 Installation Dimension(mm) Reference Value				許容回転数(rpm) Allowable Maximum Speed(rpm)		重量(g) 参考 Weight(g) Reference
d	D	D1	B	C	r _s (min)	シールド形 Shields	接触シール形 Contact Rubber Seal	Cr (N)	Cor (N)	Da (max)	da (max)	da (min)	R (min)	ZZ	2RS	
5	8	9.2	2.5	0.6	0.10	SSMF85ZZ	—	310	120	7.4	5.8	—	0.10	43000	—	0.41
	9	10.2	3	0.6	0.15	SSMF95ZZ	2RS	430	168	8.2	6.0	—	0.15	40000	26000	0.66
	10	11.6	4	0.8	0.10	SSMF105ZZ	2RS	430	168	8.4	6.0	—	0.20	42000	28000	1.46
	11	12.6	4	0.8	0.15	SSMF115ZZ	2RS	715	276	9.8	6.3	—	0.15	40000	26000	1.67
	11	12.5	5	1.0	0.15	SSF685ZZ	2RS	770	320	9.9	6.2	—	0.15	43000	40000	2.18
	13	15.0	4	1.0	0.20	SSF695ZZ	2RS	1070	420	11.2	6.6	—	0.20	43000	40000	2.84
6	14	16.0	5	1.0	0.20	SSF605ZZ	2RS	1330	505	12.2	6.9	—	0.20	40000	38000	3.85
	10	11.2	3	0.6	0.15	SSMF106ZZ	2RS	495	218	9.3	7.0	—	0.15	37000	24000	0.77
	12	13.6	4	0.8	0.10	SSMF126ZZ	2RS	715	292	10.9	7.2	—	0.20	35000	23000	1.94
	13	15.0	5	1.1	0.15	SSF686ZZ	2RS	1080	440	11.7	7.4	—	0.20	40000	38000	3.04
	15	17.0	5	1.2	0.20	SSF696ZZ	2RS	1730	570	13.3	7.9	—	0.30	40000	38000	4.26
	17	19.0	6	1.2	0.30	SSF606ZZ	2RS	2260	835	14.8	8.2	—	0.30	38000	34000	6.61
7	14	16.0	5	1.1	0.15	SSF687ZZ	2RS	1170	510	12.7	8.5	—	0.15	35000	23000	3.37
	17	19.0	5	1.2	0.30	SSF697ZZ	2RS	1610	710	14.8	10.2	—	0.30	36000	28000	5.65
	19	22.0	6	1.5	0.30	SSF607ZZ	2RS	2800	1060	16.5	9.1	—	0.30	36000	32000	8.66
	12	13.6	3.5	0.8	0.15	SSMF128ZZ	2RS	545	274	11.3	9.0	—	0.15	30000	20000	1.15
8	14	15.6	4	0.8	0.15	SSMF148ZZ	2RS	820	385	12.8	9.2	—	0.20	30000	20000	2.39
	16	18.0	5	1.1	0.20	SSF688ZZ	2RS	1610	710	14.2	10.2	—	0.20	36000	28000	4.47
	19	22.0	6	1.5	0.30	SSF698ZZ	2RS	2240	910	16.5	10.0	—	0.30	36000	28000	8.30
	22	25.0	7	1.5	0.30	SSF608ZZ	2RS	3300	1370	19.0	10.5	—	0.30	34000	28000	13.50
9	17	19.0	5	1.1	0.20	SSF689ZZ	2RS	1330	660	15.2	11.5	—	0.20	36000	24000	4.91
	20	23.0	6	1.5	0.30	SSF699ZZ	2RS	1720	840	17.2	12.0	—	0.30	34000	24000	9.51
	24	27.0	7	1.5	0.30	SSF609ZZ	2RS	3330	1410	20.5	12.0	—	0.30	32000	24000	16.00

Cr=基本動定格荷重 Cor=基本静定格荷重

Cr=Basic dynamic rated load Cor=Basic static rated load

※上記型番以外も製造可能です。お気軽にお問い合わせください。

※We can also produce bearings not in the list. Please contact us.

※接触シール形(2RS)の接触量は各社異なります。

※Different companies have differences on the quantity of contact seal (2RS).

ステンレスベアリング STAINLESS BEARINGS



深溝玉軸受

DEEP GROOVE BALL BEARINGS

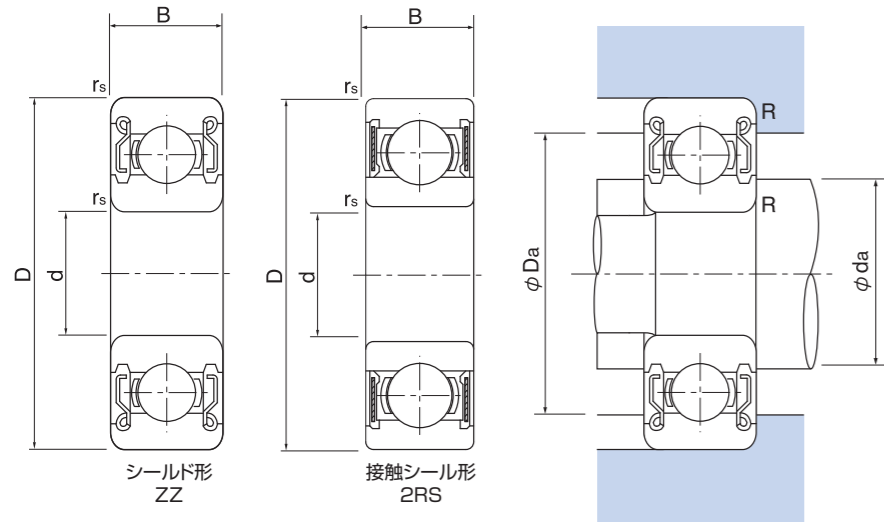

標準仕様 Standard Specification

内外輪 Inner and Outer Rings	SUS440C(相当) (equivalent)
ボール Ball	SUS440C(相当) (equivalent)
保持器 Cage	SUS304(相当) (equivalent)
シールド Shields	SUS304(相当) (equivalent)
シール Seals	SUS304(相当)+ニトリルゴム SUS304(equivalent)+Nitrile Rubber
潤滑油 Lubricant	リチウム系グリース Lithium greases
精度等級 Accuracy Class	JIS 0級 JIS 0 Class
すきま Clearance	CN CN Clearance
耐熱温度 Heat-Resistant Temperature	ZZ 120°C(参考値) 2RS 100°C(参考値)

RoHS 10

主要寸法(mm) Main Dimensions (mm)				型番 Bearing Number		基本定格荷重 Basic Load Rating		取付関係寸法(mm)参考値 Installation Dimension(mm) Reference Value				許容回転数(rpm) Allowable Maximum Speed(rpm)		重量(g) 参考 Weight(g) Reference
d	D	B	rs (min)	シールド形 Shields	接触シール形 Contact Seals	Cr(N)	Cor(N)	Da (max)	da (max)	da (min)	R (max)	ZZ	2RS	
10	19	5	0.3	SS6800ZZ	2RS	1456	736	17.0	12.0	12.0	0.30	37000	24000	5
	22	6	0.3	SS6900ZZ	2RS	1992	904	20.0	12.5	12.0	0.30	33000	22000	9
	26	8	0.3	SS6000ZZ	2RS	3640	1576	24.0	13.0	12.0	0.30	30000	22000	18
	30	9	0.3	SS6200ZZ	2RS	4080	1912	26.0	16.0	14.0	0.60	25000	18000	32
	35	11	0.5	SS6300ZZ	2RS	6480	2760	31.0	16.5	14.0	0.60	23000	17000	52
12	21	5	0.3	SS6801ZZ	2RS	1528	832	19.0	14.0	14.0	0.30	32000	20000	6
	24	6	0.3	SS6901ZZ	2RS	2160	1056	22.0	14.5	14.0	0.30	30000	20000	10
	28	8	0.3	SS6001ZZ	2RS	4080	1912	26.0	15.5	14.0	0.30	30000	20000	23
	32	10	0.3	SS6201ZZ	2RS	5440	2440	28.0	17.0	16.0	0.60	22000	17000	37
	37	12	0.5	SS6301ZZ	2RS	7840	3400	32.0	18.0	17.0	1.00	20000	16000	60
15	24	5	0.3	SS6802ZZ	2RS	1656	1000	22.0	17.0	17.0	0.30	28000	17000	7
	28	7	0.3	SS6902ZZ	2RS	3440	1800	26.0	17.0	17.0	0.30	26000	17000	15
	32	9	0.3	SS6002ZZ	2RS	4480	2272	30.0	19.0	17.0	0.30	24000	16000	32
	35	11	0.3	SS6202ZZ	2RS	6120	2960	31.0	20.5	19.0	0.60	24000	15000	45
	42	13	0.5	SS6302ZZ	2RS	9120	4320	37.0	22.5	20.0	1.00	17000	13000	82
17	26	5	0.3	SS6803ZZ	2RS	1704	1088	24.0	19.0	19.0	0.30	26000	15000	7
	30	7	0.3	SS6903ZZ	2RS	3680	2040	28.0	19.5	19.0	0.30	24000	15000	17
	35	10	0.3	SS6003ZZ	2RS	4800	2600	33.0	21.5	19.0	0.30	22000	14000	39
	40	12	0.5	SS6203ZZ	2RS	7640	3840	36.0	23.5	21.0	0.60	22000	14000	65
	47	14	0.5	SS6303ZZ	2RS	10880	5240	42.0	25.5	22.0	1.00	16000	11000	115

Cr=基本動定格荷重 Cor=基本静定格荷重
Cr=Basic dynamic rated load Cor=Basic static rated load
※上記型番以外にも製造可能です。お気軽にお問い合わせください。
※We can also produce bearings not in the list. Please contact us.

※接触シール形(2RS)の接触量は各社異なります。
※Different companies have differences on the quantity of contact seal (2RS).

主要寸法(mm) Main Dimensions (mm)				型番 Bearing Number		基本定格荷重 Basic Load Rating		取付関係寸法(mm)参考値 Installation Dimension(mm) Reference Value				許容回転数(rpm) Allowable Maximum Speed(rpm)		重量(g) 参考 Weight(g) Reference
d	D	B	rs (min)	シールド形 Shields	接触シール形 Contact Seals	Cr(N)	Cor(N)	Da (max)	da (max)	da (min)	R (max)	ZZ	2RS	
20	32	7	0.3	SS6804ZZ	2RS	2784	1792	30.0	22.0	22.0	0.30	22000	13000	17
	37	9	0.3	SS6904ZZ	2RS	5080	2960	35.0	24.0	22.0	0.30	19000	12000	37
	42	12	1.0	SS6004ZZ	2RS	7520	4000	38.0	25.5	24.0	0.60	18000	11000	70
	47	14	0.5	SS6204ZZ	2RS	10240	5280	42.0	26.5	25.0	1.00	16000	11000	106
	52	15	0.5	SS6304ZZ	2RS	12720	6320	45.5	28.0	26.5	1.00	14000	10000	144
25	37	7	0.3	SS6805ZZ	2RS	2944	2104	35.0	27.0	27.0	0.30	18000	10000	21
	42	9	0.3	SS6905ZZ	2RS	5600	3600	40.0	28.5	27.0	0.30	16000	10000	42
	47	12	0.8	SS6005ZZ	2RS	8080	4680	43.0	30.0	29.0	0.60	15000	9500	79
	52	15	1.0	SS6205ZZ	2RS	11200	6320	47.0	32.0	30.0	1.00	13000	9000	128
	62	17	0.5	SS6305ZZ	2RS	18880	9680	55.5	36.0	31.5	1.00	12000	8100	232
30	42	7	0.3	SS6806ZZ	2RS	4000	3150	40.0	32.0	32.0	0.3	15000	9000	26
	47	9	0.3	SS6906ZZ	2RS	7240	5010	45.0	34.0	32.0	0.3	14000	8500	49
	55	13	1.0	SS6006ZZ	2RS	11900	7460	50.0	36.5	35.0	1.0	13000	8000	90
	62	16	1.0	SS6206ZZ	2RS	19460	11310	57.0	38.5	35.0	1.0	11000	7500	205
	72	19	1.1	SS6306ZZ	2RS	27000	15200	65.5	42.5	36.5	1.0	9500	6700	340
35	47	7	0.3	SS6807ZZ	2RS	4270	3600	45.0	37.0	37.0	0.3	14000	7500	30
	55	10	0.6	SS6907ZZ	2RS	10390	7160	51.0	39.0	39.0	0.6	12000	7500	86
	62	14	1.0	SS6007ZZ	2RS	16210	10420	57.0	41.5	40.0	1.0	11000	6700	100
	72	17	1.1	SS6207ZZ	2RS	25670	15300	65.5	44.5	41.5	1.0	9500	6300	284
	80	21	1.5	SS6307ZZ	2RS	33500	19200	72.0	47.0	43.0	1.5	8500	6000	464
40	52	7	0.3	SS6808ZZ	2RS	4410	3890	50.0	42.0	42.0	0.3	12000	6700	30
	62	12	0.6	SS6908ZZ	2RS	13020	9200	58.0	46.0	44.0	0.6	11000	6300	112
	68	15	1.0	SS6008ZZ	2RS	17030	11700	63.0	47.5	45.0	1.0	10000	6000	190
	80	18	1.1	SS6208ZZ	2RS	29520	18140	73.5	50.5	46.5	1.0	8500	5600	366
	90	23	1.5	SS6308ZZ	2RS	40500	24000	82.0	53.0	48.0	1.5	7500	5300	636
45	58	7	0.3	SS6809ZZ	2RS	4590	4330	56.0	47.5	47.0	0.3	11000	6000	40
	68	12	0.6	SS6909ZZ	2RS	13490	10130	64.0	50.0	49.0	0.6	9500	5600	126
	75	16	1.0	SS6009ZZ	2RS	21080	14780	70.0	53.5	50.0	1.0	9000	5600	240
	85	19	1.1	SS6209ZZ	2RS	31500	20400	78.8	55.5	51.5	1.0	7500	5300	420
	100	25	1.5	SS6309ZZ	2RS	53000	32000	92.0	61.5	43.0	1.5	6700	4800	829
50	65	7	0.6	SS6810ZZ	2RS	6610	6080	63.0	52.5	52.0	0.6	9500	5300	57
	72	12	0.6	SS6910ZZ	2RS	13900	10990	68.0	55.0	54.0	0.6	9000	5300	135
	80	16	1.0	SS6010ZZ	2RS	22000	16260	75.0	58.5	55.0	1.0	8500	5000	260
	90	20	1.1	SS6210ZZ	2RS	35000	23200	83.5	60.0	56.5	1.0	7100	4800	459
	110	27	2.0	SS6310ZZ	2RS	62000	38500	101.0	68.0	59.0	2.0	6000	4300	1060

Cr=基本動定格荷重 Cor=基本静定格荷重
Cr=Basic dynamic rated load Cor=Basic static rated load
※上記型番以外にも製造可能です。お気軽にお問い合わせください。
※We can also produce bearings not in the list. Please contact us.

※接触シール形(2RS)の接触量は各社異なります。
※Different companies have differences on the quantity of contact seal (2RS).

セラミックベアリング

CERAMIC BEARINGS

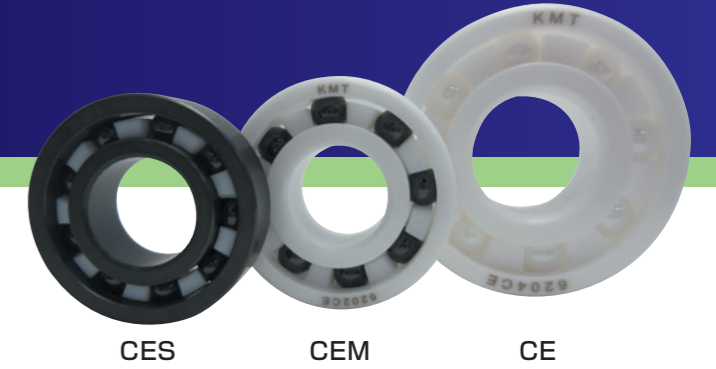

セラミック軸受

CERAMIC BEARINGS

標準仕様

Standard Specification

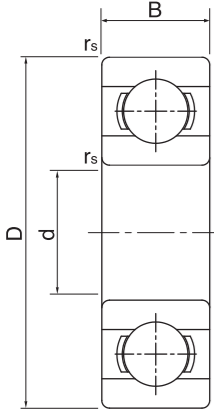

ジルコニア (CE)		窒化ケイ素 (CES)		ジルコニア+窒化ケイ素 (CEM)		ハイブリッド (HYB)	
内外輪 Inner and Outer Rings	ZrO ₂	内外輪 Inner and Outer Rings	Si ₃ N ₄	内外輪 Inner and Outer Rings	ZrO ₂	内外輪 Inner and Outer Rings	SUS440C(相当) (equivalent)
ボール Ball	ZrO ₂	ボール Ball	Si ₃ N ₄	ボール Ball	Si ₃ N ₄	ボール Ball	Si ₃ N ₄
保持器 Cage	PTFE	保持器 Cage	PTFE	保持器 Cage	PTFE	保持器 Cage	SUS304(相当) (equivalent)
すきま Clearance	CN~C3	すきま Clearance	CN~C3	すきま Clearance	CN~C3	シールド Shields	SUS304(相当) (equivalent)
耐熱温度 Heat-Resistant Temperature	180°C	耐熱温度 Heat-Resistant Temperature	180°C	耐熱温度 Heat-Resistant Temperature	180°C	すきま Clearance	CN~C3
RoHS 10						潤滑油 Lubricant	リチウム系グリース Lithium Greases
						耐熱温度 Heat-Resistant Temperature	150°C

●セラミックの材料特性、組み合わせ特性表は、技術資料をご参照ください。

●セラミックの材料特性、組み合わせ特性表は、技術資料をご参照ください。

主要寸法 (mm) Main Dimensions				型番 Bearing Number				許容ラジアル荷重 (参考値) (N) Allowable Radial Load Reference Value				許容回転数 (参考値) (rpm) Allowable Maximum Speed Reference Value				重量 (g) 参考 Weight (g) Reference			
d	D	B	rs (min)	CE	CES	CEM	HYB	CE	CES	CEM	HYB	CE	CES	CEM	HYB	CE	CES	CEM	HYB
5	11	3	0.2	685CE	CES	CEM	HYB	5	6	5	13	1000	1000	1000	1000	0.9	0.5	0.8	1.0
	13	4	0.2	695CE	CES	CEM	HYB	8	9	8	19	1000	1000	1000	1000	1.9	1.0	1.8	2.3
	14	5	0.2	605CE	CES	CEM	HYB	9	12	9	23	1000	1000	1000	1000	2.7	1.5	2.5	3.2
	16	5	0.2	625CE	CES	CEM	HYB	12	15	12	30	1000	1000	1000	1000	3.8	2.1	3.5	4.5
	19	6	0.3	635CE	CES	CEM	HYB	16	21	16	41	1000	1000	1000	1000	6.6	3.6	6.0	7.7
6	13	3.5	0.3	686CE	CES	CEM	HYB	8	9	8	19	1000	1000	1000	1000	1.5	0.8	1.4	1.7
	15	5	0.2	696CE	CES	CEM	HYB	12	15	12	30	1000	1000	1000	1000	3.0	1.6	2.7	3.4
	17	6	0.3	606CE	CES	CEM	HYB	16	20	16	40	1000	1000	1000	1000	4.7	2.5	4.3	5.5
	19	6	0.3	626CE	CES	CEM	HYB	16	21	16	41	1000	1000	1000	1000	6.3	3.4	5.7	7.3
	22	7	0.3	636CE	CES	CEM	HYB	23	29	23	58	1000	1000	1000	1000	11.0	5.8	9.8	12.6
7	14	3.5	0.15	687CE	CES	CEM	HYB	8	10	8	21	1000	1000	1000	1000	1.7	0.9	1.6	2.0
	17	5	0.3	697CE	CES	CEM	HYB	11	14	11	28	1000	1000	1000	1000	4.0	2.2	3.6	4.6
	19	6	0.3	607CE	CES	CEM	HYB	16	21	16	41	1000	1000	1000	1000	5.9	3.2	5.4	6.4
	22	7	0.3	627CE	CES	CEM	HYB	23	29	23	58	1000	1000	1000	1000	9.8	5.3	8.9	11.4
	26	9	0.3	637CE	CES	CEM	HYB	28	35	28	71	1000	1000	1000	1000	19.0	10.0	17.0	21.9

※許容ラジアル荷重、許容回転数は参考値であり保証値ではありません。
 ※Allowable Radial Load, Allowable Maximum Speed information above are references, not guaranteed.

※上記以外の組み合わせも可能です。お気軽にお問い合わせください。
 ※We can also produce bearings not in the list. Please contact us.

※はめ合いは、基本すきまばめにしてください。
 ※The fitness style is basically clearance fitness style.

※セラミックは衝撃に弱い材質ですので、取扱いに注意してください。
 ※Ceramics is very weak to impact, please be careful about the handing.

主要寸法 (mm) Main Dimensions				型番 Bearing Number				許容ラジアル荷重 (参考値) (N) Allowable Radial Load Reference Value				許容回転数 (参考値) (rpm) Allowable Maximum Speed Reference Value				重量 (g) 参考 Weight (g) Reference			
d	D	B	rs (min)	CE	CES	CEM	HYB	CE	CES	CEM	HYB	CE	CES	CEM	HYB	CE	CES	CEM	HYB
8	16	4	0.2	688CE	CES	CEM	HYB	9	11	9	22	1000	1000	1000	1000	2.5	1.4	2.3	2.9
	19	6	0.3	698CE	CES	CEM	HYB	16	20	16	39	1000	1000	1000	1000	5.6	3.0	5.0	6.4
	22	7	0.3	608CE	CES	CEM	HYB	23	29	23	58	1000	1000	1000	1000	9.3	5.0	8.4	10.8
	24	8	0.3	628CE	CES	CEM	HYB	23	29	23	59	1000	1000	1000	1000	13.0	7.2	12.0	15.0
	28	9	0.3	638CE	CES	CEM	HYB	32	40	32	80	1000	1000	1000	1000	22.0	12.0	20.0	25.8
9	17	4	0.2	689CE	CES	CEM	HYB	9	12	9	23	1000	1000	1000	1000	2.7	1.5	2.5	3.2
	20	6	0.3	699CE	CES	CEM	HYB	12	15	12	30	1000	1000	1000	1000	6.5	3.5	5.9	7.6
	24	7	0.3	609CE	CES	CEM	HYB	23	29	23	59	1000	1000	1000	1000	11.0	6.0	9.9	12.7
	26	8	0.3	629CE	CES	CEM	HYB	32	40	32	80	1000	1000	1000	1000	15.0	8.1	14.0	17.8
10	19	5	0.3	6800CE	CES	CEM	HYB	10	12	10	24	850	850	850	850	4.0	2.2	3.6	4.6
	22	6	0.3	6900CE	CES	CEM	HYB	14	17	14	34	850	850	850	850	7.0	3.9	6.3	8.1
	26	8	0.3	6000CE	CES	CEM	HYB	32	40	32	81	850	850	850	850	14.0	7.7	13.0	16.8
	30	9	0.6	6200CE	CES	CEM	HYB	35	44	35	89	850	850	850	850	25.0	14.0	23.0	29.7
	35	11	0.6	6300CE	CES	CEM	HYB	56	71	56	141	850	850	850	850	40.0	22.0	36.0	46.5
	12	21	5	0.3	6801CE	CES	CEM	HYB	10	13	10	25	750	750	750	750	5.0	2.8	4.5
24		6	0.3	6901CE	CES	CEM	HYB	16	20	16	39	750	750	750	750	8.0	4.4	7.2	9.3
28		8	0.3	6001CE	CES	CEM	HYB	35	44	35	89	750	750	750	750	17.0	9.4	15.0	19.0
32		10	0.6	6201CE	CES	CEM	HYB	48	60	48	121	750	750	750	750	28.0	15.0	25.0	32.0
37		12	1.0	6301CE	CES	CEM	HYB	68	85	68	171	750	750	750	750	46.0	25.0	41.0	52.8
15		24	5	0.3	6802CE	CES	CEM	HYB	11	14	11	27	600	600	600	600	5.0	2.8	4.5
	28	7	0.3	6902CE	CES	CEM	HYB	28	35	28	71	600	600	600	600	12.0	6.6	11.0	14.0
	32	9	0.3	6002CE	CES	CEM	HYB	39	49	39	98	600	600	600	600	24.0	13.0	22.0	28.0
	35	11	0.6	6202CE	CES	CEM	HYB	55	68	55	137	600	600	600	600	35.0	19.0	32.0	41.0
	42	13	1.0	6302CE	CES	CEM	HYB	80	100	80	200	600	600	600	600	64.0	35.0	58.0	75.0

※許容ラジアル荷重、許容回転数は参考値であり保証値ではありません。
 ※Allowable Radial Load, Allowable Maximum Speed information above are references, not guaranteed.

※上記以外の組み合わせも可能です。お気軽にお問い合わせください。
 ※We can also produce bearings not in the list. Please contact us.

※はめ合いは、基本すきまばめにしてください。
 ※The fitness style is basically clearance fitness style.

※セラミックは衝撃に弱い材質ですので、取扱いに注意してください。
 ※Ceramics is very weak to impact, please be careful about the handing.

セラミックベアリング

CERAMIC BEARINGS

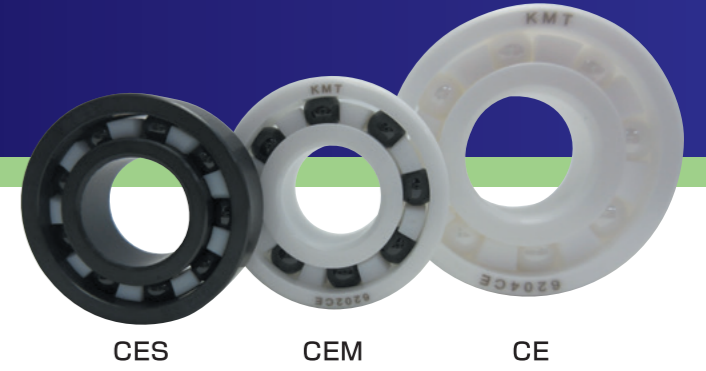

セラミック軸受

CERAMIC BEARINGS

■標準仕様 Standard Specification

	ジルコニア (CE)	窒化ケイ素 (CES)	ジルコニア+窒化ケイ素 (CEM)	ハイブリッド (HYB)
内外輪 Inner and Outer Rings	ZrO ₂	内外輪 Inner and Outer Rings Si ₃ N ₄	ZrO ₂	SUS440C(相当) (equivalent)
ボール Ball	ZrO ₂	ボール Ball Si ₃ N ₄	ボール Ball Si ₃ N ₄	ボール Ball Si ₃ N ₄
保持器 Cage	PTFE	保持器 Cage PTFE	保持器 Cage PTFE	保持器 Cage SUS304(相当) (equivalent)
すきま Clearance	CN~C3	すきま Clearance CN~C3	すきま Clearance CN~C3	シールド Shields SUS304(相当) (equivalent)
耐熱温度 Heat-Resistant Temperature	180℃	耐熱温度 Heat-Resistant Temperature 180℃	耐熱温度 Heat-Resistant Temperature 180℃	すきま Clearance CN~C3
	RoHS 10			潤滑油 Lubricant リチウム系グリース Lithium Greases
				耐熱温度 Heat-Resistant Temperature 150℃

●セラミックの材料特性、組み合わせ特性表は、技術資料をご参照ください。

●セラミックの材料特性、組み合わせ特性表は、技術資料をご参照ください。

主要寸法 (mm) Main Dimensions				型番 Bearing Number				許容ラジアル荷重 (参考値) (N) Allowable Radial Load Reference Value				許容回転数 (参考値) (rpm) Allowable Maximum Speed Reference Value				重量 (g) 参考 Weight (g) Reference			
d	D	B	r _s (min)	CE	CES	CEM	HYB	CE	CES	CEM	HYB	CE	CES	CEM	HYB	CE	CES	CEM	HYB
17	26	5	0.3	6803CE	CES	CEM	HYB	12	15	12	29	500	500	500	500	5.0	2.8	4.5	6.2
	30	7	0.3	6903CE	CES	CEM	HYB	31	38	31	76	500	500	500	500	13.0	7.2	12.0	15.4
	35	10	0.3	6003CE	CES	CEM	HYB	42	53	42	106	500	500	500	500	32.0	18.0	26.0	33.5
	40	12	0.6	6203CE	CES	CEM	HYB	67	84	67	167	500	500	500	500	52.0	29.0	47.0	60.6
	47	14	1.0	6303CE	CES	CEM	HYB	74	92	74	184	500	500	500	500	87.0	48.0	78.0	100.0
20	32	7	0.3	6804CE	CES	CEM	HYB	19	24	19	47	450	450	450	450	13.0	7.2	12.0	15.8
	37	9	0.3	6904CE	CES	CEM	HYB	45	56	45	112	450	450	450	450	28.0	15.0	25.0	32.0
	42	12	0.6	6004CE	CES	CEM	HYB	66	82	66	164	450	450	450	450	52.0	29.0	47.0	61.0
	47	14	1.0	6204CE	CES	CEM	HYB	89	111	89	222	450	450	450	450	82.0	45.0	74.0	95.0
	52	15	1.1	6304CE	CES	CEM	HYB	111	139	111	278	450	450	450	450	110.0	61.0	99.0	128.0
25	37	7	0.3	6805CE	CES	CEM	HYB	31	38	31	76	350	350	350	350	16.0	8.8	14.0	18.0
	42	9	0.3	6905CE	CES	CEM	HYB	46	58	46	116	350	350	350	350	32.0	18.0	29.0	37.2
	47	12	0.6	6005CE	CES	CEM	HYB	78	98	78	196	350	350	350	350	61.0	34.0	55.0	71.0
	52	15	1.0	6205CE	CES	CEM	HYB	98	123	98	245	350	350	350	350	99.0	55.0	89.0	115.0
	62	17	1.1	6305CE	CES	CEM	HYB	158	197	158	394	350	350	350	350	180.0	99.0	162.0	208.0

※許容ラジアル荷重、許容回転数は参考値であり保証値ではありません。
 ※Allowable Radial Load, Allowable Maximum Speed information above are references, not guaranteed.

※上記以外の組み合わせも可能です。お気軽にお問い合わせください。
 ※We can also produce bearings not in the list. Please contact us.

※はめ合いは、基本すきまばめにしてください。
 ※The fitness style is basically clearance fitness style.

※セラミックは衝撃に弱い材質ですので、取扱いに注意してください。
 ※Ceramics is very weak to impact, please be careful about the handling.

主要寸法 (mm) Main Dimensions				型番 Bearing Number				許容ラジアル荷重 (参考値) (N) Allowable Radial Load Reference Value				許容回転数 (参考値) (rpm) Allowable Maximum Speed Reference Value				重量 (g) 参考 Weight (g) Reference			
d	D	B	r _s (min)	CE	CES	CEM	HYB	CE	CES	CEM	HYB	CE	CES	CEM	HYB	CE	CES	CEM	HYB
30	42	7	0.3	6806CE	CES	CEM	HYB	31	39	31	79	300	300	300	300	18.0	10.0	16.0	20.5
	47	9	0.3	6906CE	CES	CEM	HYB	51	64	51	127	300	300	300	300	40.0	22.0	36.0	44.0
	55	13	1.0	6006CE	CES	CEM	HYB	93	116	93	233	300	300	300	300	89.0	48.0	80.0	102.0
	62	16	1.0	6206CE	CES	CEM	HYB	137	171	137	341	300	300	300	300	150.0	83.0	135.0	173.0
	72	19	1.1	6306CE	CES	CEM	HYB	197	246	197	492	300	300	300	300	270.0	140.0	243.0	312.0
35	47	7	0.3	6807CE	CES	CEM	HYB	33	42	33	83	200	200	200	200	21.0	11.0	19.0	24.0
	55	10	0.6	6907CE	CES	CEM	HYB	67	84	67	167	200	200	200	200	58.0	31.0	52.0	66.8
	62	14	1.0	6007CE	CES	CEM	HYB	111	139	111	278	200	200	200	200	120.0	63.0	108.0	139.0
	72	17	1.1	6207CE	CES	CEM	HYB	179	223	179	446	200	200	200	200	220.0	120.0	198.0	254.0
	80	21	1.5	6307CE	CES	CEM	HYB	232	291	232	581	200	200	200	200	360.0	190.0	324.0	416.0
40	52	7	0.3	6808CE	CES	CEM	HYB	35	43	35	86	200	200	200	200	20.0	13.0	18.0	23.0
	62	12	0.6	6908CE	CES	CEM	HYB	97	121	97	242	200	200	200	200	90.0	50.0	81.0	104.0
	68	15	1.0	6008CE	CES	CEM	HYB	118	147	118	294	200	200	200	200	150.0	80.0	135.0	172.0
	80	18	1.1	6208CE	CES	CEM	HYB	215	269	215	537	200	200	200	200	280.0	150.0	252.0	320.0
	90	23	1.5	6308CE	CES	CEM	HYB	287	359	287	718	200	200	200	200	490.0	270.0	441.0	569.0
45	58	7	0.3	6809CE	CES	CEM	HYB	42	53	42	106	150	150	150	150	29.0	16.0	26.0	33.0
	68	12	0.6	6909CE	CES	CEM	HYB	71	88	71	177	150	150	150	150	97.0	53.0	87.0	112.0
	75	16	1.0	6009CE	CES	CEM	HYB	146	182	146	364	150	150	150	150	190.0	100.0	171.0	220.0
	85	19	1.1	6209CE	CES	CEM	HYB	232	291	232	581	150	150	150	150	320.0	175.0	288.0	368.0
	100	25	1.5	6309CE	CES	CEM	HYB	369	461	369	922	150	150	150	150	640.0	345.0	576.0	740.0
50	65	7	0.3	6810CE	CES	CEM	HYB	44	55	44	109	150	150	150	150	38.0	21.0	34.0	43.8
	72	12	0.6	6910CE	CES	CEM	HYB	102	128	102	256	150	150	150	150	100.0	60.0	90.0	115.5
	80	16	1.0	6010CE	CES	CEM	HYB	151	189	151	378	150	150	150	150	200.0	110.0	180.0	230.0
	90	20	1.1	6210CE	CES	CEM	HYB	246	307	246	614	150	150	150	150	350.0	190.0	315.0	401.0
	110	27	2.0	6310CE	CES	CEM	HYB	433	541	433	1082	150	150	150	150	820.0	440.0	738.0	948.0

※許容ラジアル荷重、許容回転数は参考値であり保証値ではありません。
 ※Allowable Radial Load, Allowable Maximum Speed information above are references, not guaranteed.

※上記以外の組み合わせも可能です。お気軽にお問い合わせください。
 ※We can also produce bearings not in the list. Please contact us.

※はめ合いは、基本すきまばめにしてください。
 ※The fitness style is basically clearance fitness style.

※セラミックは衝撃に弱い材質ですので、取扱いに注意してください。
 ※Ceramics is very weak to impact, please be careful about the handling.

ベアリングユニット

BEARING UNITS

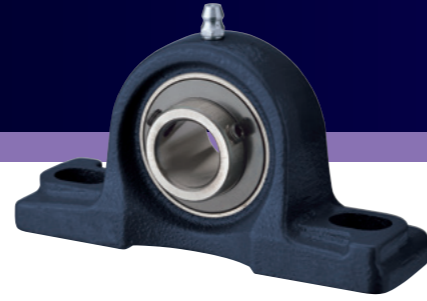

ピロー形ユニット〈UCP形〉

PILLOW UNITS 〈UCP〉

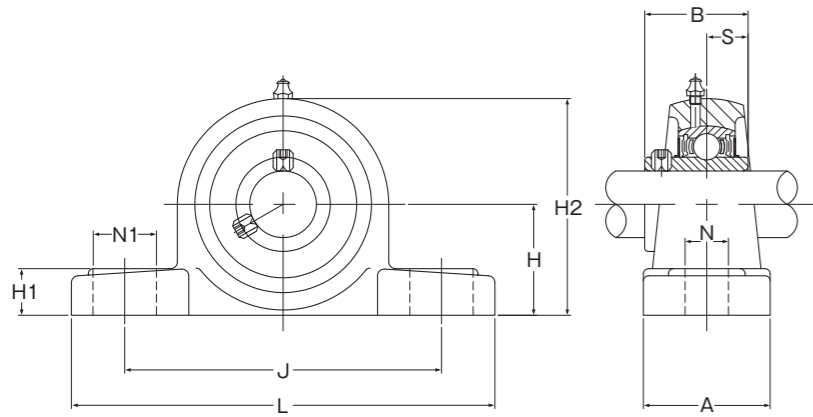

- 標準仕様
Standard Specification
- 軸受 Bearing SUJ2(相当)
(equivalent)
 - 軸受箱 Housing FC200(相当)
(equivalent)
 - 潤滑油 Lubricant リチウム系グリース
Lithium Greases
 - 耐熱温度 Heat-Resistant Temperature 110℃(参考値)

RoHS 10

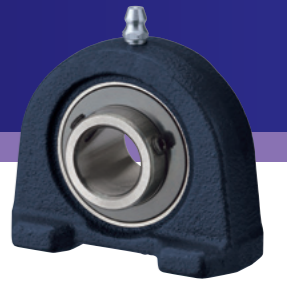

ピロー形ユニット〈UCPA形〉

PILLOW UNITS 〈UCPA〉

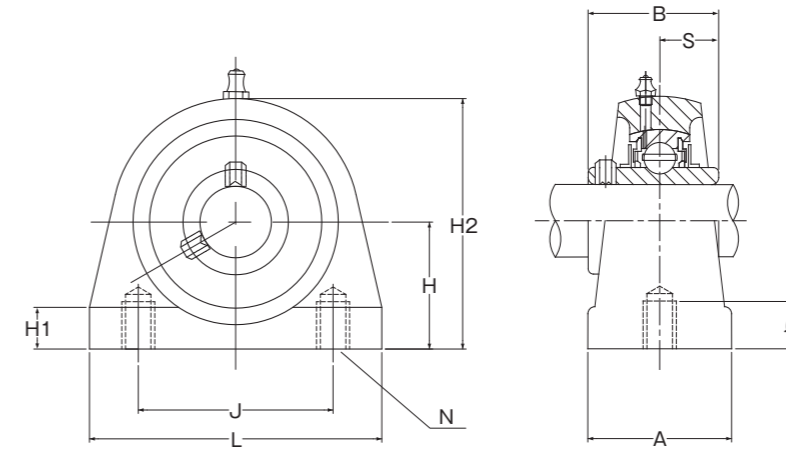

- 標準仕様
Standard Specification
- 軸受 Bearing SUJ2(相当)
(equivalent)
 - 軸受箱 Housing FC200(相当)
(equivalent)
 - 潤滑油 Lubricant リチウム系グリース
Lithium Greases
 - 耐熱温度 Heat-Resistant Temperature 110℃(参考値)

RoHS 10

軸径 Shaft Dia (mm)	ユニット型番 Unit Number	主要寸法(mm) Main Dimensions (mm)										取付け ボルト サイズ Bolt Size	軸受箱 型番 Housing Number	軸受 型番 Bearing Number	重量 (kg) Weight (Kg) Reference
		H	L	A	J	N	N1	H1	H2	B	S				
17	UCP203	30.2	127	38	95	13	19	14	62	31.0	12.7	M10	P203	UC203	0.60
20	UCP204	33.3	127	38	96	13	19	14	65	31.0	12.7	M10	P204	UC204	0.66
25	UCP205	36.5	140	38	105	13	19	15	71	34.1	14.3	M10	P205	UC205	0.80
30	UCP206	42.9	165	48	121	17	21	17	83	38.1	15.9	M14	P206	UC206	1.20
35	UCP207	47.6	167	48	127	17	21	18	93	42.9	17.5	M14	P207	UC207	1.70
40	UCP208	49.2	184	54	137	17	21	18	98	49.2	19.0	M14	P208	UC208	2.10
45	UCP209	54.0	190	54	146	17	21	20	106	49.2	19.0	M14	P209	UC209	2.40
50	UCP210	57.2	206	60	159	20	25	21	114	51.6	19.0	M16	P210	UC210	2.90

※上記型番以外も製造可能です。お気軽にお問い合わせください。
※We can also produce bearings not in the list. Please contact us.

軸径 Shaft Dia (mm)	ユニット型番 Unit Number	主要寸法(mm) Main Dimensions (mm)										軸受箱 型番 Housing Number	軸受 型番 Bearing Number	重量 (kg) Weight (Kg) Reference
		H	L	A	J	N	H1	H2	l	B	S			
17	UCPA203	30.2	76	38	52	M10×1.5	8	62	14	31.0	12.7	PA203	UC203	0.60
20	UCPA204	30.2	76	38	52	M10×1.5	8	62	14	31.0	12.7	PA204	UC204	0.60
25	UCPA205	36.5	84	38	56	M10×1.5	10	72	15	34.1	14.3	PA205	UC205	0.80
30	UCPA206	42.9	94	48	66	M14×2.0	10	84	18	38.1	15.9	PA206	UC206	1.25
35	UCPA207	47.6	110	48	80	M14×2.0	12	95	20	42.9	17.5	PA207	UC207	1.70
40	UCPA208	49.2	116	54	84	M14×2.0	12	100	20	49.2	19.0	PA208	UC208	2.00
45	UCPA209	54.2	120	54	90	M14×2.0	12	108	20	49.2	19.0	PA209	UC209	2.20
50	UCPA210	57.2	130	60	94	M16×2.0	14	116	25	51.6	19.0	PA210	UC210	2.80

※上記型番以外も製造可能です。お気軽にお問い合わせください。
※We can also produce bearings not in the list. Please contact us.

ベアリングユニット

BEARING UNITS



ひしフランジ形ユニット〈UCFL形〉

RHOMBUS FLANGED UNITS 〈UCFL〉

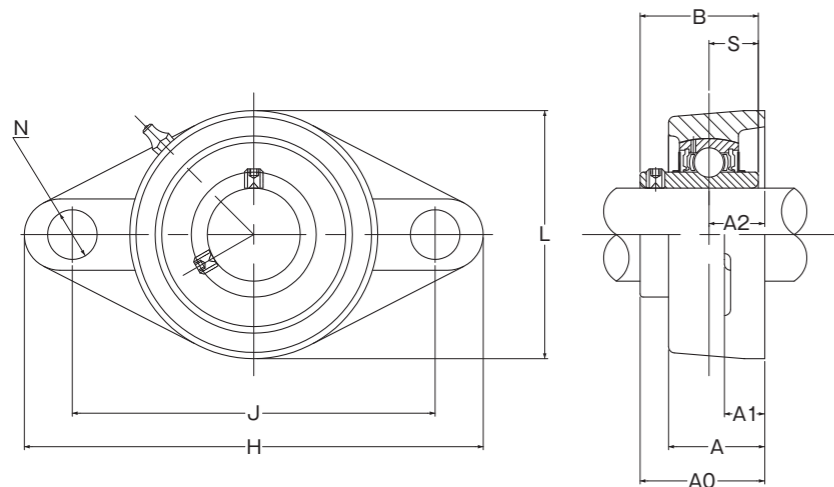

- 標準仕様
Standard Specification
- 軸受 Bearing SUJ2(相当)
(equivalent)
 - 軸受箱 Housing FC200(相当)
(equivalent)
 - 潤滑油 Lubricant リチウム系グリース
Lithium Greases
 - 耐熱温度 Heat-Resistant Temperature 110℃(参考値)

RoHS 10

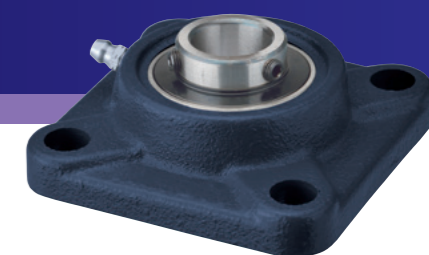

角フランジ形ユニット〈UCF形〉

SQUARE FLANGED UNITS 〈UCF〉

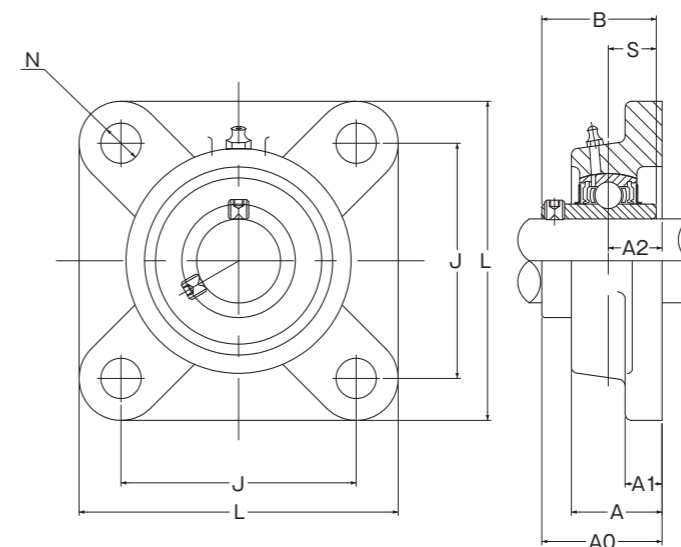

- 標準仕様
Standard Specification
- 軸受 Bearing SUJ2(相当)
(equivalent)
 - 軸受箱 Housing FC200(相当)
(equivalent)
 - 潤滑油 Lubricant リチウム系グリース
Lithium Greases
 - 耐熱温度 Heat-Resistant Temperature 110℃(参考値)

RoHS 10

軸径 Shaft Dia (mm)	ユニット型番 Unit Number	主要寸法(mm) Main Dimensions (mm)										取付け ボルト サイズ Bolt Size	軸受箱 型番 Housing Number	軸受 型番 Bearing Number	重量 (kg) Weight (Kg) Reference
		H	L	A	J	N	A0	A1	A2	B	S				
17	UCFL203	113	60	25.5	90	12	33.3	12	15	31.0	12.7	M10	FL203	UC203	0.49
20	UCFL204	113	60	25.5	90	12	33.3	12	15	31.0	12.7	M10	FL204	UC204	0.47
25	UCFL205	130	68	27	99	16	35.8	14	16	34.1	14.3	M14	FL205	UC205	0.63
30	UCFL206	148	80	31	117	16	40.2	13	18	38.1	15.9	M14	FL206	UC206	0.85
35	UCFL207	161	90	34	130	16	44.4	16	19	42.9	17.5	M14	FL207	UC207	1.20
40	UCFL208	175	100	36	144	16	51.2	16	21	49.2	19.0	M14	FL208	UC208	1.60
45	UCFL209	188	108	38	148.5	19	52.2	18	22	49.2	19.0	M16	FL209	UC209	1.90
50	UCFL210	197	115	40	157	19	54.6	18	22	51.6	19.0	M16	FL210	UC210	2.30

※上記型番以外も製造可能です。お気軽にお問い合わせください。
※We can also produce bearings not in the list. Please contact us.

軸径 Shaft Dia (mm)	ユニット型番 Unit Number	主要寸法(mm) Main Dimensions (mm)										取付け ボルト サイズ Bolt Size	軸受箱 型番 Housing Number	軸受 型番 Bearing Number	重量 (kg) Weight (Kg) Reference
		L	A	J	N	A0	A1	A2	B	S					
17	UCF203	86	25.5	64	12	33.3	12	15	31.0	12.7	M10	F203	UC203	0.62	
20	UCF204	86	25.5	64	12	33.3	12	15	31.0	12.7	M10	F204	UC204	0.60	
25	UCF205	95	27	70	12	35.8	14	16	34.1	14.3	M10	F205	UC205	0.86	
30	UCF206	108	31	83	12	40.2	14	18	38.1	15.9	M10	F206	UC206	1.10	
35	UCF207	117	34	92	14	44.4	16	19	42.9	17.5	M12	F207	UC207	1.60	
40	UCF208	130	36	102	16	51.2	16	21	49.2	19.0	M14	F208	UC208	1.90	
45	UCF209	137	38	105	16	52.2	18	22	49.2	19.0	M14	F209	UC209	2.40	
50	UCF210	143	40	111	16	54.6	18	22	51.6	19.0	M14	F210	UC210	2.60	

※上記型番以外も製造可能です。お気軽にお問い合わせください。
※We can also produce bearings not in the list. Please contact us.

ステンレスベアリングユニット

STAINLESS BEARING UNITS

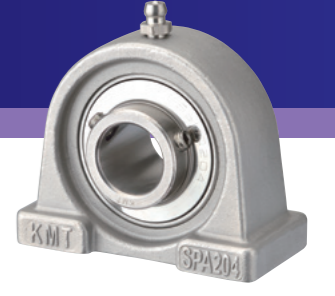

ピロー形ユニット〈SUCP形〉

PILLOW UNITS 〈SUCP〉

インロー加工無しタイプ

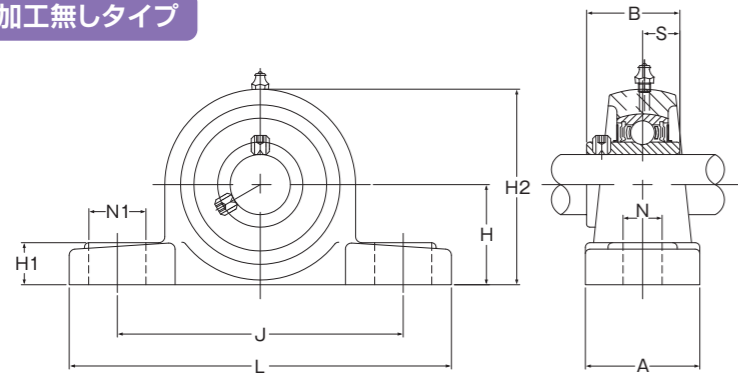

■標準仕様

Standard Specification

軸受 Bearing SUS440C(相当) (equivalent)
 軸受箱 Housing SCS13(相当) (equivalent)
 潤滑油 Lubricant H1 認証食品用グリース H1 Certificated Grease For Food
 耐熱温度 Heat-Resistant Temperature 120℃(参考値)

RoHS 10

インロー加工付きタイプ

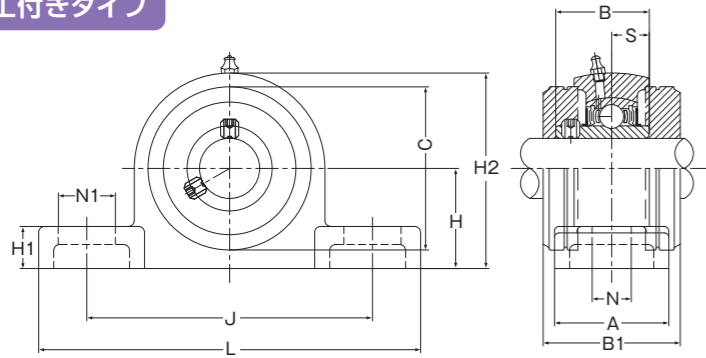

Cカバー Dカバー

※C・D カバーは別途購入

型式 Cカバー:SSUC***-C
 型式 Dカバー:SSUC***-D

※Cカバーのゴムは赤茶色のニトリルゴム製
 ※順次、インロー加工付きタイプへ仕様変更

ピロー形ユニット〈SUCPA形〉

PILLOW UNITS 〈SUCPA〉

インロー加工無しタイプ

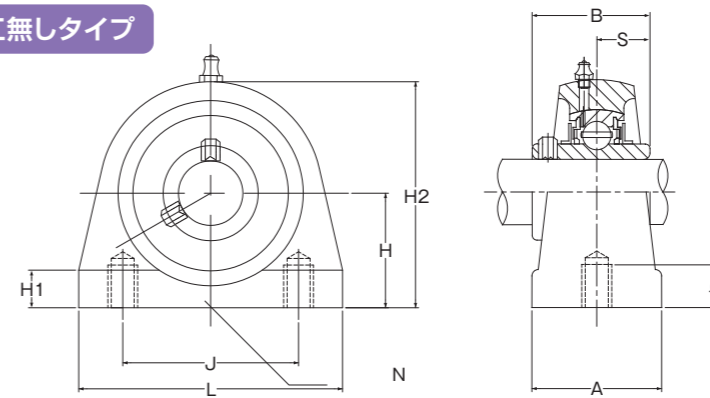

■標準仕様

Standard Specification

軸受 Bearing SUS440C(相当) (equivalent)
 軸受箱 Housing SCS13(相当) (equivalent)
 潤滑油 Lubricant H1 認証食品用グリース H1 Certificated Grease For Food
 耐熱温度 Heat-Resistant Temperature 120℃(参考値)

RoHS 10

インロー加工付きタイプ

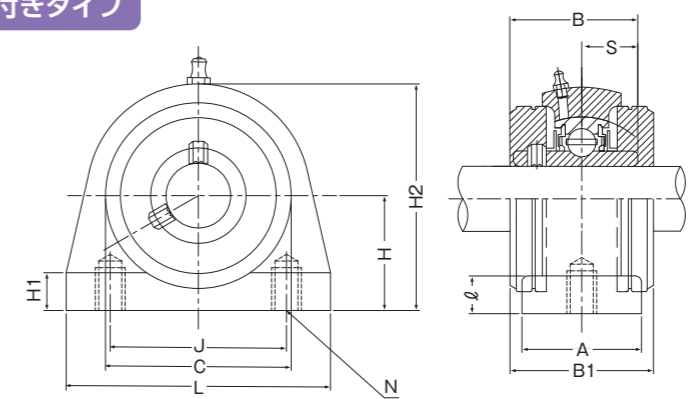

Cカバー Dカバー

※C・D カバーは別途購入

型式 Cカバー:SSUC***-C
 型式 Dカバー:SSUC***-D

※Cカバーのゴムは赤茶色のニトリルゴム製
 ※順次、インロー加工付きタイプへ仕様変更

軸径 Shaft Dia (mm)	ユニット型番 Unit Number	主要寸法(mm) Main Dimensions (mm)											取付け ボルト サイズ Bolt Size	軸受箱 型番 Housing Number	軸受 型番 Bearing Number	重量 (kg) Weight (kg) Reference	
		H	C	L	A	J	N	N1	H1	H2	B	B1					S
17	SUCP203	30.2	-	127	38	95	13	19	14	65	31.0	-	12.7	M10	SP203	SSUC203	0.69
	SUCP203インロー	30.2	54.3	127	38	95	13	19	14	62	31.0	45.6	12.7	M10	SP203	SSUC203	0.61
20	SUCP204	33.3	-	127	38	95	13	19	14	65	31.0	-	12.7	M10	SP204	SSUC204	0.67
	SUCP204インロー	33.3	54.3	127	38	95	13	19	14	65	31.0	45.6	12.7	M10	SP204	SSUC204	0.59
25	SUCP205	36.5	-	140	38	105	13	19	15	71	34.1	-	14.3	M10	SP205	SSUC205	0.83
	SUCP205インロー	36.5	60.3	140	38	105	13	19	15	71	34.1	47.8	14.3	M10	SP205	SSUC205	0.69
30	SUCP206	42.9	-	165	48	121	17	21	17	84	38.1	-	15.9	M14	SP206	SSUC206	1.32
	SUCP206インロー	42.9	70.4	165	48	121	17	21	17	84	38.1	52.8	15.9	M14	SP206	SSUC206	1.16
35	SUCP207	47.6	-	167	48	127	17	21	18	93	42.9	-	17.5	M14	SP207	SSUC207	1.55
	SUCP207インロー	47.6	80.4	167	48	127	17	21	18	93	42.9	57.4	17.5	M14	SP207	SSUC207	1.36
40	SUCP208	49.2	-	184	54	137	17	23	18	100	49.2	-	19.0	M14	SP208	SSUC208	1.91
	SUCP208インロー	49.2	88.2	184	54	137	17	23	18	100	49.2	66.8	19.0	M14	SP208	SSUC208	1.68
45	SUCP209	54.0	-	190	54	146	17	23	20	106	49.2	-	19.0	M14	SP209	SSUC209	2.21
	SUCP209インロー	54.0	95.2	190	54	146	17	23	20	106	49.2	67.8	19.0	M14	SP209	SSUC209	1.94
50	SUCP210	57.2	-	206	60	159	20	25	21	113	51.6	-	19.0	M16	SP210	SSUC210	2.82
	SUCP210インロー	57.2	100.1	206	60	159	20	25	21	113	51.6	75.6	19.0	M16	SP210	SSUC210	2.48

※上記型番以外も製造可能です。お気軽にお問い合わせください。
 ※We can also produce bearings not in the list. Please contact us.

軸径 Shaft Dia (mm)	ユニット型番 Unit Number	主要寸法(mm) Main Dimensions (mm)											取付け ボルト サイズ Bolt Size	軸受箱 型番 Housing Number	軸受 型番 Bearing Number	重量 (kg) Weight (kg) Reference	
		H	C	L	A	J	N	φ	H1	H2	B	B1					S
17	SUCPA203	30.2	-	76	38	52	M10X1.5	13	10.5	62	31.0	-	12.7	M10	SPA203	SSUC203	0.54
	SUCPA203インロー	30.2	54.3	76	38	52	M10X1.5	13	10.5	62	31.0	45.6	12.7	M10	SPA203	SSUC203	0.48
20	SUCPA204	30.2	-	76	38	52	M10X1.5	13	10.5	62	31.0	-	12.7	M10	SPA204	SSUC204	0.52
	SUCPA204インロー	30.2	54.3	76	38	52	M10X1.5	13	10.5	62	31.0	45.6	12.7	M10	SPA204	SSUC204	0.46
25	SUCPA205	36.5	-	84	38	56	M10X1.5	13	12.5	72	34.1	-	14.3	M10	SPA205	SSUC205	0.73
	SUCPA205インロー	36.5	60.3	84	38	56	M10X1.5	13	12.5	72	34.1	47.8	14.3	M10	SPA205	SSUC205	0.64
30	SUCPA206	42.9	-	94	50	66	M14X2	18	12.5	84	38.1	-	15.9	M14	SPA206	SSUC206	1.09
	SUCPA206インロー	42.9	70.4	94	50	66	M14X2	18	12.5	84	38.1	52.8	15.9	M14	SPA206	SSUC206	0.96
35	SUCPA207	47.6	-	110	55	80	M14X2	20	13.5	95	42.9	-	17.5	M14	SPA207	SSUC207	1.53
	SUCPA207インロー	47.6	80.4	110	55	80	M14X2	20	13.5	95	42.9	57.4	17.5	M14	SPA207	SSUC207	1.35
40	SUCPA208	49.2	-	116	58	84	M14X2	20	13.5	100	49.2	-	19.0	M14	SPA208	SSUC208	1.77
	SUCPA208インロー	49.2	88.2	116	58	84	M14X2	20	13.5	100	49.2	66.8	19.0	M14	SPA208	SSUC208	1.56
45	SUCPA209	54.2	-	120	60	90	M14X2	25	13.5	108	49.2	-	19.0	M14	SPA209	SSUC209	2.04
	SUCPA209インロー	54.2	95.2	120	60	90	M14X2	25	13.5	108	49.2	67.8	19.0	M14	SPA209	SSUC209	1.80
50	SUCPA210	57.2	-	130	64	94	M16X2	25	14.5	116	51.6	-	19.0	M16	SPA210	SSUC210	2.38
	SUCPA210インロー	57.2	100.1	130	64	94	M16X2	25	14.5	116	51.6	75.6	19.0	M16	SPA210	SSUC210	2.09

※上記型番以外も製造可能です。お気軽にお問い合わせください。
 ※We can also produce bearings not in the list. Please contact us.

ステンレス ベ어링ユニット

STAINLESS BEARING UNITS



ひしフランジ形ユニット〈SUCFL形〉

RHOMBUS FLANGED UNITS 〈SUCFL〉

インロー加工無しタイプ

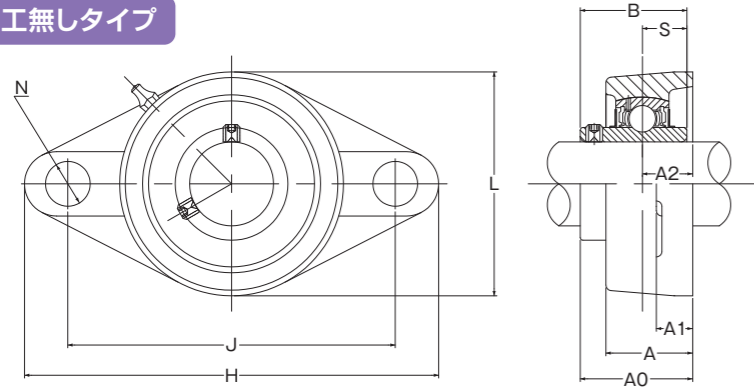

■標準仕様

Standard Specification

軸受 Bearing SUS440C(相当) (equivalent)
 軸受箱 Housing SCS13(相当) (equivalent)
 潤滑油 Lubricant H1 認証食品用グリース (H1 Certificated Grease For Food)
 耐熱温度 Heat-Resistant Temperature 120℃(参考値)

RoHS 10

インロー加工付きタイプ

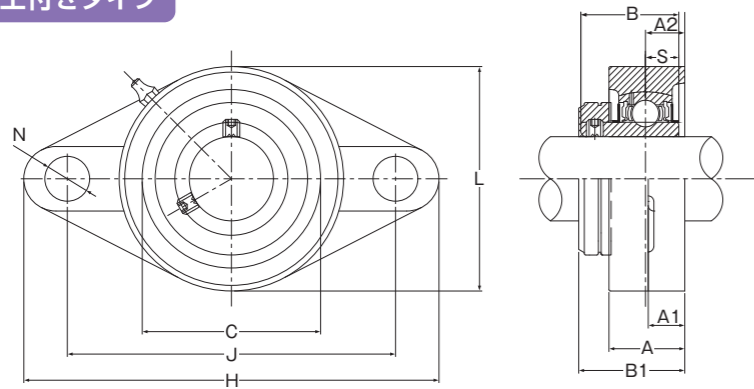

Cカバー

※Cカバーは別途購入

型式:SSUC***-C

※Cカバーのゴムは赤茶色のニトリルゴム製
 ※順次、インロー加工付きタイプへ仕様変更

角フランジ形ユニット〈SUCF形〉

SQUARE FLANGED UNITS 〈SUCF〉

インロー加工無しタイプ

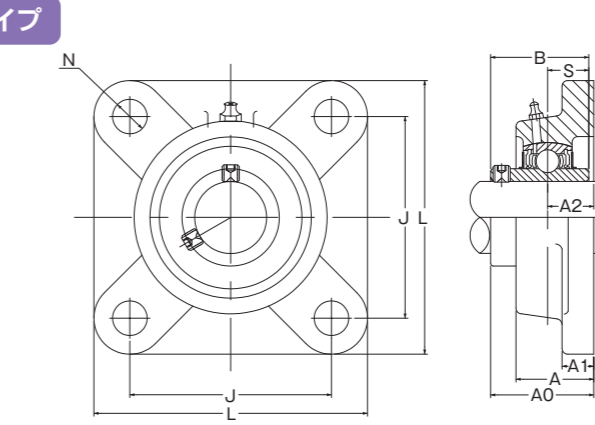

■標準仕様

Standard Specification

軸受 Bearing SUS440C(相当) (equivalent)
 軸受箱 Housing SCS13(相当) (equivalent)
 潤滑油 Lubricant H1 認証食品用グリース (H1 Certificated Grease For Food)
 耐熱温度 Heat-Resistant Temperature 120℃(参考値)

RoHS 10

インロー加工付きタイプ

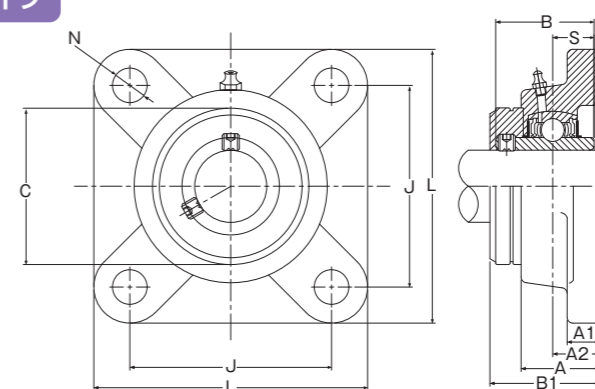

Cカバー

※Cカバーは別途購入

型式:SSUC***-C

※Cカバーのゴムは赤茶色のニトリルゴム製
 ※順次、インロー加工付きタイプへ仕様変更

軸径 Shaft Dia (mm)	ユニット型番 Unit Number	主要寸法(mm) Main Dimensions (mm)											取付け ボルト サイズ Bolt Size	軸受箱 型番 Housing Number	軸受 型番 Bearing Number	重量 (kg) Weight (kg) Reference	
		H	C	L	A	J	N	A0	A1	A2	B	B1					S
17	SUCFL203	113	-	60	27	90	12	33.3	11	15	31.0	-	12.7	M10	SFL203	SSUC203	0.53
	SUCFL203インロー	113	54.3	60	27	90	12	-	11	15	31.0	37.8	12.7	M10	SFL203	SSUC203	0.47
20	SUCFL204	113	-	60	27	90	12	33.3	11	15	31.0	-	12.7	M10	SFL204	SSUC204	0.50
	SUCFL204インロー	113	54.3	60	26	90	12	-	11	15	31.0	37.8	12.7	M10	SFL204	SSUC204	0.44
25	SUCFL205	130	-	68	28	99	16	35.8	13	16	34.1	-	14.3	M14	SFL205	SSUC205	0.70
	SUCFL205インロー	130	60.3	68	27	99	16	-	13	16	34.1	39.9	14.3	M14	SFL205	SSUC205	0.61
30	SUCFL206	148	-	78	31	117	16	40.2	13	18	38.1	-	15.9	M14	SFL206	SSUC206	1.02
	SUCFL206インロー	148	70.4	78	31	117	16	-	13	18	38.1	44.4	15.9	M14	SFL206	SSUC206	0.90
35	SUCFL207	161	-	88	34	130	16	44.4	15	19	42.9	-	17.5	M14	SFL207	SSUC207	1.36
	SUCFL207インロー	161	80.4	88	34	130	16	-	15	19	42.9	48.7	17.5	M14	SFL207	SSUC207	1.19
40	SUCFL208	175	-	96	36	144	16	51.2	15	21	49.2	-	19.0	M14	SFL208	SSUC208	1.68
	SUCFL208インロー	175	88.2	96	36	144	16	-	15	21	49.2	54.9	19.0	M14	SFL208	SSUC208	1.48
45	SUCFL209	188	-	104	38	148	19	52.2	16	22	49.2	-	19.0	M16	SFL209	SSUC209	2.00
	SUCFL209インロー	188	95.2	104	38	148	19	-	16	22	49.2	56.9	19.0	M16	SFL209	SSUC209	1.76
50	SUCFL210	197	-	111	40	157	19	54.6	16	22	51.6	-	19.0	M16	SFL210	SSUC210	2.30
	SUCFL210インロー	197	100.1	111	40	157	19	-	16	22	51.6	61.8	19.0	M16	SFL210	SSUC210	2.03

※上記型番以外も製造可能です。お気軽にお問い合わせください。
 ※We can also produce bearings not in the list. Please contact us.

軸径 Shaft Dia (mm)	ユニット型番 Unit Number	主要寸法(mm) Main Dimensions (mm)											取付け ボルト サイズ Bolt Size	軸受箱 型番 Housing Number	軸受 型番 Bearing Number	重量 (kg) Weight (kg) Reference	
		H	C	L	A	J	N	A0	A1	A2	B	B1					S
17	SUCF203	-	-	86	27	64	12	33.3	12	15	31.0	-	12.7	M10	SF203	SSUC203	0.71
	SUCF203インロー	-	54.3	86	26	64	12	-	12	15	31.0	37.8	12.7	M10	SF203	SSUC203	0.62
20	SUCF204	-	-	86	27	64	12	33.3	12	15	31.0	-	12.7	M10	SF204	SSUC204	0.68
	SUCF204インロー	-	54.3	86	26	64	12	-	12	15	31.0	37.8	12.7	M10	SF204	SSUC204	0.60
25	SUCF205	-	-	95	27	70	12	35.8	14	16	34.1	-	14.3	M10	SF205	SSUC205	0.88
	SUCF205インロー	-	60.3	95	27	70	12	-	14	16	34.1	39.9	14.3	M10	SF205	SSUC205	0.77
30	SUCF206	-	-	108	31	83	12	40.2	14	18	38.1	-	15.9	M10	SF206	SSUC206	1.21
	SUCF206インロー	-	70.4	108	31	83	12	-	14	18	38.1	44.4	15.9	M10	SF206	SSUC206	1.07
35	SUCF207	-	-	117	34	92	14	44.4	16	19	42.9	-	17.5	M12	SF207	SSUC207	1.62
	SUCF207インロー	-	80.4	117	34	92	14	-	16	19	42.9	48.7	17.5	M12	SF207	SSUC207	1.43
40	SUCF208	-	-	130	36	102	16	51.2	16	21	49.2	-	19.0	M14	SF208	SSUC208	2.09
	SUCF208インロー	-	88.2	130	36	102	16	-	16	21	49.2	54.9	19.0	M14	SF208	SSUC208	1.84
45	SUCF209	-	-	137	38	105	16	52.2	18	22	49.2	-	19.0	M14	SF209	SSUC209	2.50
	SUCF209インロー	-	95.2	137	38	105	16	-	18	22	49.2	56.9	19.0	M14	SF209	SSUC209	2.20
50	SUCF210	-	-	143	40	111	16	54.6	18	22	51.6	-	19.0	M14	SF210	SSUC210	2.64
	SUCF210インロー	-	100.1	143	40	111	16	-	18	22	51.6	61.8	19.0	M14	SF210	SSUC210	2.33

※上記型番以外も製造可能です。お気軽にお問い合わせください。
 ※We can also produce bearings not in the list. Please contact us.

軽量形ベアリングユニット〈偏心カラータイプ〉

LIGHT BEARING UNITS

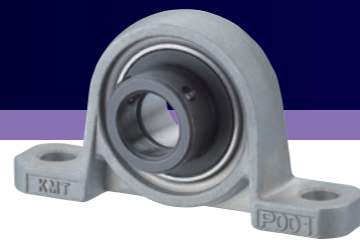

ピロー形ユニット〈UP形〉

PILLOW UNITS 〈UP〉

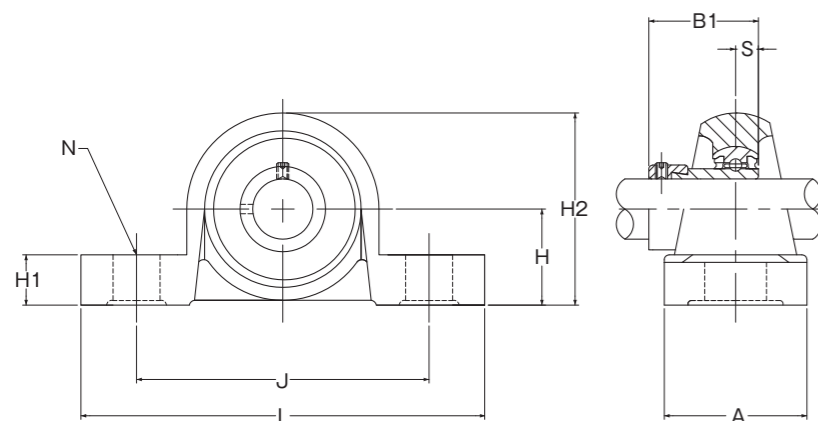

- 標準仕様
Standard Specification
- 軸受 Bearing: SUJ2(相当) (equivalent)
 - 軸受箱 Housing: ZDC2(相当) (equivalent)
 - 潤滑油 Lubricant: リチウム系グリース (Lithium Greases)
 - 耐熱温度 Heat-Resistant Temperature: 110℃(参考値)

RoHS 10

ひしフランジ形ユニット〈UFL形〉

RHOMBUS FLANGED UNITS 〈UFL〉

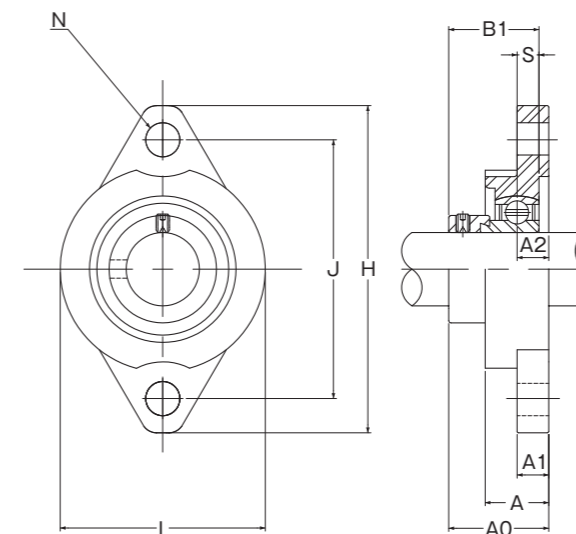

- 標準仕様
Standard Specification
- 軸受 Bearing: SUJ2(相当) (equivalent)
 - 軸受箱 Housing: ZDC2(相当) (equivalent)
 - 潤滑油 Lubricant: リチウム系グリース (Lithium Greases)
 - 耐熱温度 Heat-Resistant Temperature: 110℃(参考値)

RoHS 10

偏心カラータイプ

ECCENTRIC COLLAR TYPE

軸径 Shaft Dia (mm)	ユニット型番 Unit Number	主要寸法(mm) Main Dimensions (mm)									取付け ボルト サイズ Bolt Size	軸受箱 型番 Housing Number	軸受 型番 Bearing Number	重量 (kg) Weight (kg) Reference
		H	L	A	J	N	H1	H2	B1	S				
10	UP000	18	67	16	53	7	6	35	17.5	4.0	M6	P000	U000	0.07
12	UP001	19	71	16	56	7	6	38	17.5	4.0	M6	P001	U001	0.08
15	UP002	22	80	16	63	7	7	43	18.5	4.5	M6	P002	U002	0.11
17	UP003	24	85	18	67	7	7	47	20.5	5.0	M6	P003	U003	0.15
20	UP004	28	100	20	80	10	9	55	24.5	6.0	M8	P004	U004	0.23
25	UP005	32	112	20	90	10	10	62	25.5	6.0	M8	P005	U005	0.28
30	UP006	36	132	26	106	13	11	70	26.5	6.5	M10	P006	U006	0.38

偏心カラータイプ

ECCENTRIC COLLAR TYPE

軸径 Shaft Dia (mm)	ユニット型番 Unit Number	主要寸法(mm) Main Dimensions (mm)										取付け ボルト サイズ Bolt Size	軸受箱 型番 Housing Number	軸受 型番 Bearing Number	重量 (kg) Weight (kg) Reference
		H	L	A	J	N	A0	A1	A2	B1	S				
10	UFL000	60	36	11.5	45	7	19	5.5	5.5	17.5	4.0	M6	FL000	U000	0.06
12	UFL001	63	38	11.5	48	7	19	5.5	5.5	17.5	4.0	M6	FL001	U001	0.07
15	UFL002	67	42	13	53	7	20.5	6.5	6.5	18.5	4.5	M6	FL002	U002	0.09
17	UFL003	71	46	14	56	7	22.5	7	7	20.5	5.0	M6	FL003	U003	0.12
20	UFL004	90	55	16	71	10	26.5	8	8	24.5	6.0	M8	FL004	U004	0.21
25	UFL005	95	60	16	75	10	27.5	8	8	25.5	6.0	M8	FL005	U005	0.24
30	UFL006	112	70	18	85	13	29.0	9	9	26.5	6.5	M10	FL006	U006	0.35

軽量形ベアリングユニット〈止めねじタイプ〉

LIGHT BEARING UNITS

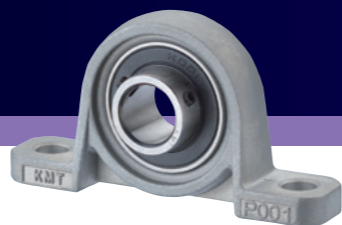

ピロー形ユニット〈KP形〉

PILLOW UNITS 〈KP〉

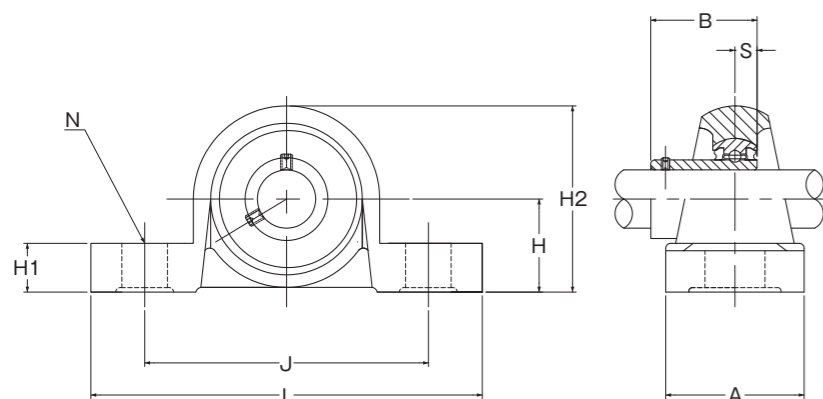

- 標準仕様
Standard Specification
- 軸受 Bearing SUJ2(相当)
(equivalent)
 - 軸受箱 Housing ZDC2(相当)
(equivalent)
 - 潤滑油 Lubricant リチウム系グリース
Lithium Greases
 - 耐熱温度 Heat-Resistant Temperature 110℃(参考値)

RoHS 10

ひしフランジ形ユニット〈KFL形〉

RHOMBUS FLANGED UNITS 〈KFL〉

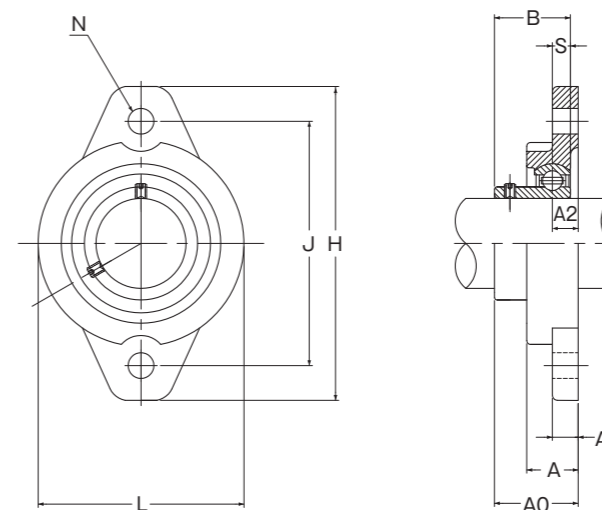

- 標準仕様
Standard Specification
- 軸受 Bearing SUJ2(相当)
(equivalent)
 - 軸受箱 Housing ZDC2(相当)
(equivalent)
 - 潤滑油 Lubricant リチウム系グリース
Lithium Greases
 - 耐熱温度 Heat-Resistant Temperature 110℃(参考値)

RoHS 10

止めねじタイプ

SET SCREW TYPE

軸径 Shaft Dia (mm)	ユニット型番 Unit Number	主要寸法(mm) Main Dimensions (mm)									取付け ボルト サイズ Bolt Size	軸受箱 型番 Housing Number	軸受 型番 Bearing Number	重量 (kg) Weight (kg) Reference
		H	L	A	J	N	H1	H2	B	S				
10	KP000	18	67	16	53	7	6	35	14	4	M6	P000	K000	0.06
12	KP001	19	71	16	56	7	6	38	14.5	4	M6	P001	K001	0.08
15	KP002	22	80	16	63	7	7	43	16.5	4.5	M6	P002	K002	0.11
17	KP003	24	85	18	67	7	7	47	17.5	5	M6	P003	K003	0.14
20	KP004	28	100	20	80	10	9	55	21	6	M8	P004	K004	0.21
25	KP005	32	112	20	90	10	10	62	22.5	6	M8	P005	K005	0.26
30	KP006	36	132	26	106	13	11	70	24.5	6.5	M10	P006	K006	0.36

止めねじタイプ

SET SCREW TYPE

軸径 Shaft Dia (mm)	ユニット型番 Unit Number	主要寸法(mm) Main Dimensions (mm)										取付け ボルト サイズ Bolt Size	軸受箱 型番 Housing Number	軸受 型番 Bearing Number	重量 (kg) Weight (kg) Reference
		H	L	A	J	N	A0	A1	A2	B	S				
10	KFL000	60	36	11.5	45	7	15.5	5.5	5.5	14	4	M6	FL000	K000	0.05
12	KFL001	63	38	11.5	48	7	16	5.5	5.5	14.5	4	M6	FL001	K001	0.07
15	KFL002	67	42	13	53	7	18.5	6.5	6.5	16.5	4.5	M6	FL002	K002	0.09
17	KFL003	71	46	14	56	7	19.5	7	7	17.5	5	M6	FL003	K003	0.11
20	KFL004	90	55	16	71	10	23	8	8	21	6	M8	FL004	K004	0.19
25	KFL005	95	60	16	75	10	24.5	8	8	22.5	6	M8	FL005	K005	0.22
30	KFL006	112	70	18	85	13	27	8	9	24.5	6.5	M10	FL006	K006	0.33

軽量形ステンレスベアリングユニット 〈偏心カラータイプ〉

LIGHT STAINLESS BEARING UNITS

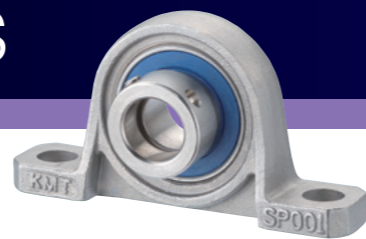

ピロー形ユニット〈SUP形〉

PILLOW UNITS 〈SUP〉

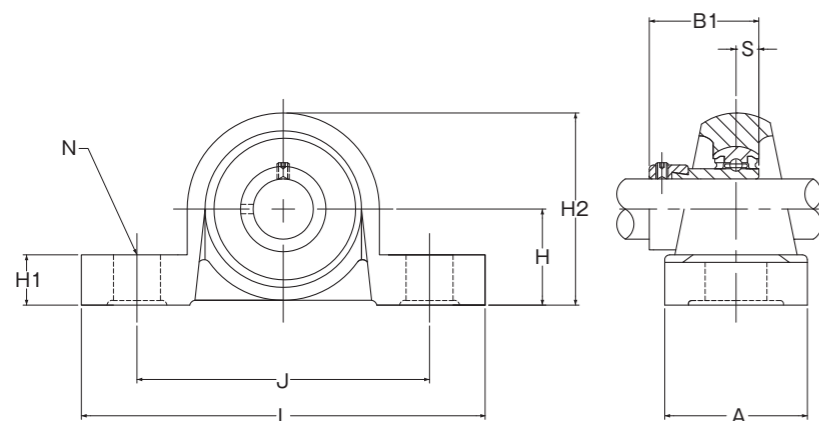

- 標準仕様
Standard Specification
- 軸受 (Bearing): SUS440C (相当) (equivalent)
 - 軸受箱 (Housing): SCS13 (相当) (equivalent)
 - 潤滑油 (Lubricant): H1 認証食品用グリース (H1 Certified Grease For Food)
 - 耐熱温度 (Heat-Resistant Temperature): 120°C (参考値)

RoHS 10

ひしフランジ形ユニット〈SUFL形〉

RHOMBUS FLANGED UNITS 〈SUFL〉

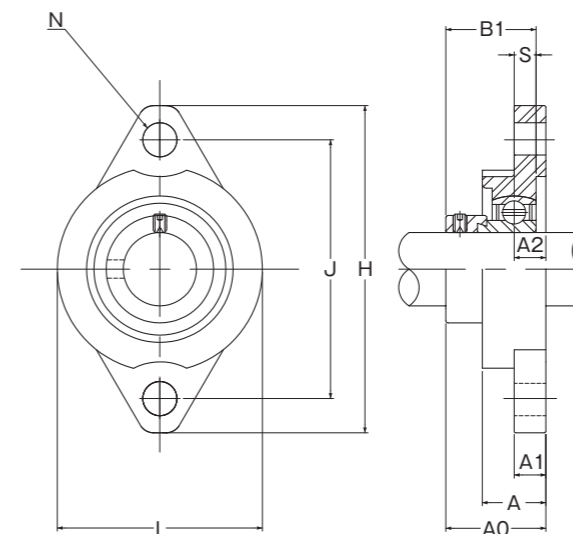

- 標準仕様
Standard Specification
- 軸受 (Bearing): SUS440C (相当) (equivalent)
 - 軸受箱 (Housing): SCS13 (相当) (equivalent)
 - 潤滑油 (Lubricant): H1 認証食品用グリース (H1 Certified Grease For Food)
 - 耐熱温度 (Heat-Resistant Temperature): 120°C (参考値)

RoHS 10

偏心カラータイプ

ECCENTRIC COLLAR TYPE

軸径 Shaft Dia (mm)	ユニット型番 Unit Number	主要寸法 (mm) Main Dimensions (mm)									取付け ボルト サイズ Bolt Size	軸受箱 型番 Housing Number	軸受 型番 Bearing Number	重量 (kg) Weight (kg) Reference
		H	L	A	J	N	H1	H2	B1	S				
10	SUP000	18	67	16	53	7	6	35	17.5	4	M6	SP000	SU000	0.09
12	SUP001	19	71	16	56	7	6	38	17.5	4	M6	SP001	SU001	0.10
15	SUP002	22	80	16	63	7	7	43	18.5	4.5	M6	SP002	SU002	0.13
17	SUP003	24	85	18	67	7	7	47	20.5	5	M6	SP003	SU003	0.16
20	SUP004	28	100	20	80	10	9	55	24.5	6	M8	SP004	SU004	0.27
25	SUP005	32	112	20	90	10	10	62	25.5	6	M8	SP005	SU005	0.35
30	SUP006	36	132	26	106	13	11	70	26.5	6.5	M10	SP006	SU006	0.53

偏心カラータイプ

ECCENTRIC COLLAR TYPE

軸径 Shaft Dia (mm)	ユニット型番 Unit Number	主要寸法 (mm) Main Dimensions (mm)										取付け ボルト サイズ Bolt Size	軸受箱 型番 Housing Number	軸受 型番 Bearing Number	重量 (kg) Weight (kg) Reference
		H	L	A	J	N	A0	A1	A2	B1	S				
10	SUFL000	60	36	11.5	45	7	19	5.5	5.5	17.5	4	M6	SFL000	SU000	0.08
12	SUFL001	63	38	11.5	48	7	19	5.5	5.5	17.5	4	M6	SFL001	SU001	0.10
15	SUFL002	67	42	13	53	7	20.5	6.5	6.5	18.5	4.5	M6	SFL002	SU002	0.11
17	SUFL003	71	46	14	56	7	22.5	7	7	20.5	5	M6	SFL003	SU003	0.14
20	SUFL004	90	55	16	71	10	26.5	8	8	24.5	6	M8	SFL004	SU004	0.25
25	SUFL005	95	60	16	75	10	27.5	8	8	25.5	6	M8	SFL005	SU005	0.28
30	SUFL006	112	70	18	85	13	29.0	9	9	26.5	6.5	M10	SFL006	SU006	0.40

軽量形ステンレスベアリングユニット 〈止めねじタイプ〉

LIGHT STAINLESS BEARING UNITS

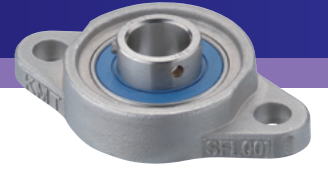
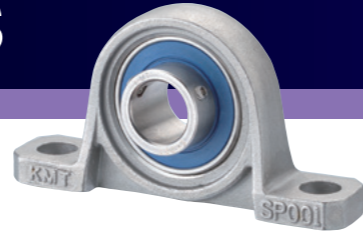

ピロー形ユニット〈SKP形〉

PILLOW UNITS 〈SKP〉

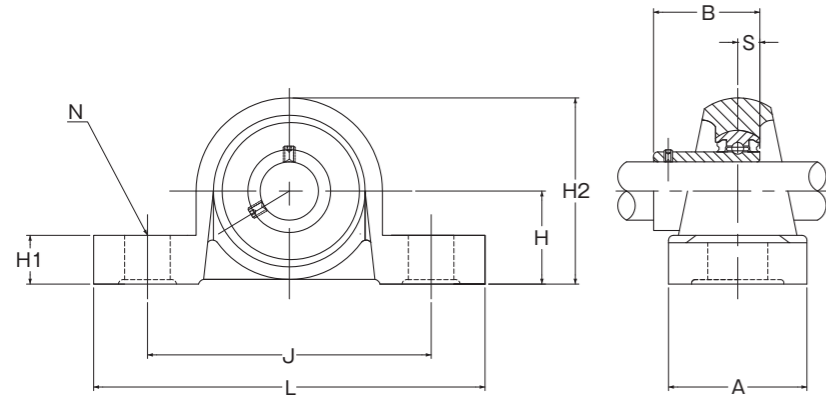

■標準仕様
Standard Specification

軸受 Bearing	SUS440C(相当) (equivalent)
軸受箱 Housing	SCS13(相当) (equivalent)
潤滑油 Lubricant	H1 認証食品用グリース H1 Certificated Grease For Food
耐熱温度 Heat-Resistant Temperature	120°C(参考値)

RoHS 10

ひしフランジ形ユニット〈SKFL形〉

RHOMBUS FLANGED UNITS 〈SKFL〉

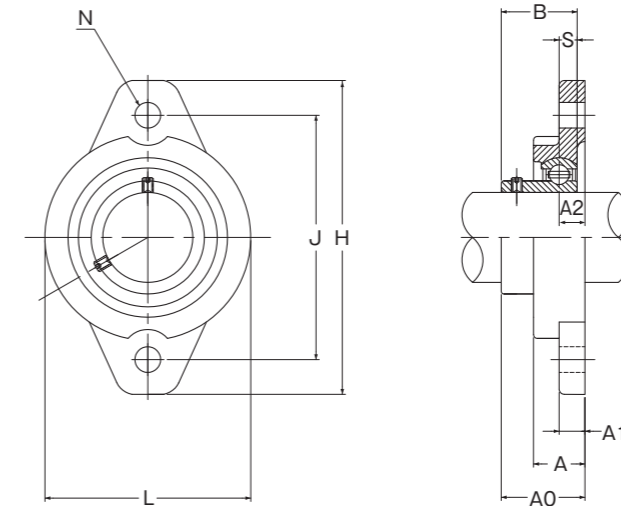

■標準仕様
Standard Specification

軸受 Bearing	SUS440C(相当) (equivalent)
軸受箱 Housing	SCS13(相当) (equivalent)
潤滑油 Lubricant	H1 認証食品用グリース H1 Certificated Grease For Food
耐熱温度 Heat-Resistant Temperature	120°C(参考値)

RoHS 10

止めねじタイプ

SET SCREW TYPE

軸径 Shaft Dia (mm)	ユニット型番 Unit Number	主要寸法(mm) Main Dimensions (mm)									取付け ボルト サイズ Bolt Size	軸受箱 型番 Housing Number	軸受 型番 Bearing Number	重量 (kg) Weight (kg) Reference
		H	L	A	J	N	H1	H2	B	S				
10	SKP000	18	67	16	53	7	6	35	14	4	M6	SP000	SK000	0.08
12	SKP001	19	71	16	56	7	6	38	14.5	4	M6	SP001	SK001	0.10
15	SKP002	22	80	16	63	7	7	43	16.5	4.5	M6	SP002	SK002	0.13
17	SKP003	24	85	18	67	7	7	47	17.5	5	M6	SP003	SK003	0.15
20	SKP004	28	100	20	80	10	9	55	21	6	M8	SP004	SK004	0.25
25	SKP005	32	112	20	90	10	10	62	22.5	6	M8	SP005	SK005	0.33
30	SKP006	36	132	26	106	13	11	70	24.5	6.5	M10	SP006	SK006	0.51

止めねじタイプ

SET SCREW TYPE

軸径 Shaft Dia (mm)	ユニット型番 Unit Number	主要寸法(mm) Main Dimensions (mm)										取付け ボルト サイズ Bolt Size	軸受箱 型番 Housing Number	軸受 型番 Bearing Number	重量 (kg) Weight (kg) Reference
		H	L	A	J	N	A0	A1	A2	B	S				
10	SKFL000	60	36	11.5	45	7	15.5	5.5	5.5	14	4	M6	SFL000	SK000	0.07
12	SKFL001	63	38	11.5	48	7	16	5.5	5.5	14.5	4	M6	SFL001	SK001	0.10
15	SKFL002	67	42	13	53	7	18.5	6.5	6.5	16.5	4.5	M6	SFL002	SK002	0.11
17	SKFL003	71	46	14	56	7	19.5	7	7	17.5	5	M6	SFL003	SK003	0.13
20	SKFL004	90	55	16	71	10	23	8	8	21	6	M8	SFL004	SK004	0.23
25	SKFL005	95	60	16	75	10	24.5	8	8	22.5	6	M8	SFL005	SK005	0.26
30	SKFL006	112	70	18	85	13	27	9	9	24.5	6.5	M10	SFL006	SK006	0.38

インサート軸受

INSERT BEARINGS

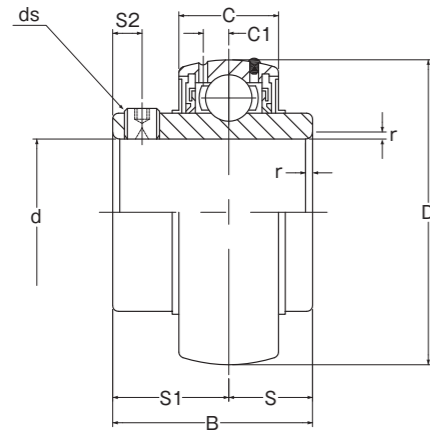

標準仕様
Standard Specification

軸受 Bearing	UC形	SUJ2(相当) (equivalent)
	SSUC形	SUS440C(相当) (equivalent)
潤滑油 Lubricant	UC形	リチウム系グリース Lithium Greases
	SSUC形	H1 認証食品用グリース H1 Certificated Grease For Food
耐熱温度 Heat-Resistant Temperature	UC形	110℃(参考値)
	SSUC形	120℃(参考値)

RoHS 10

ベアリングユニット用 (UC形)

BEARING UNITS (UC)

軸径 Shaft Dia (mm)	型番 Number	主要寸法(mm) Main Dimensions (mm)										基本定格荷重 Basic Load Rating		重量 (kg) Weight (kg) Reference
		d	D	B	C	r	S	S1	S2	ds	C1	Cr(N)	Cor(N)	
17	UC203	17	47	31	17	1.0	12.7	18.3	5	M6×0.75	4.2	12800	6600	0.18
20	UC204	20	47	31	17	1.0	12.7	18.3	5	M6×0.75	4.2	12800	6600	0.16
25	UC205	25	52	34.1	17	1.0	14.3	19.8	5	M6×0.75	4.2	14000	7800	0.19
30	UC206	30	62	38.1	19	1.0	15.9	22.2	5	M6×0.75	5.2	19500	11200	0.31
35	UC207	35	72	42.9	20	1.5	17.5	25.4	6.5	M8×1	5.6	25700	15200	0.46
40	UC208	40	80	49.2	21	1.5	19	30.2	8	M8×1	6.2	29600	18200	0.63
45	UC209	45	85	49.2	22	1.5	19	30.2	8	M8×1	6.3	31800	20800	0.68
50	UC210	50	90	51.6	24	1.5	19	32.6	10	M10×1.25	6.5	35100	23200	0.78

ステンレスベアリングユニット用 (SSUC形)

STAINLESS BEARING UNITS (SSUC)

軸径 Shaft Dia (mm)	型番 Number	主要寸法(mm) Main Dimensions (mm)										基本定格荷重 Basic Load Rating		重量 (kg) Weight (kg) Reference
		d	D	B	C	r	S	S1	S2	ds	C1	Cr(N)	Cor(N)	
17	SSUC203	17	47	31	17	1.0	12.7	18.3	4.7	M6×0.75	4.0	12700	6600	0.17
20	SSUC204	20	47	31	17	1.0	12.7	18.3	4.7	M6×0.75	4.0	12700	6600	0.15
25	SSUC205	25	52	34.1	17	1.5	14.3	19.8	5	M6×0.75	4.2	14000	7900	0.19
30	SSUC206	30	62	38.1	19	1.5	15.9	22.2	5	M6×1	5.2	19800	11300	0.30
35	SSUC207	35	72	42.9	20	1.5	17.5	25.4	7	M8×1	5.5	25600	15200	0.44
40	SSUC208	40	80	49.2	21	1.6	19	30.2	8	M8×1	6.2	29400	18000	0.59
45	SSUC209	45	85	49.2	22	1.6	19	30.2	8	M8×1	6.4	31600	20600	0.65
50	SSUC210	50	90	51.6	24	1.6	19	32.6	10	M10×1.25	6.5	35000	23200	0.73

Cr=基本動定格荷重 Cor=基本静定格荷重
Cr=Basic dynamic rated load Cor=Basic static rated load

*上記型番以外も製造可能です。お気軽にお問い合わせください。
*We can also produce bearings not in the list. Please contact us.

ステンレスベアリングユニット用カバー

STAINLESS BEARING UNITS COVER

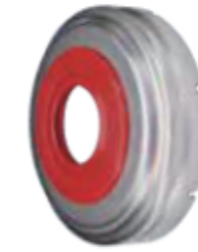
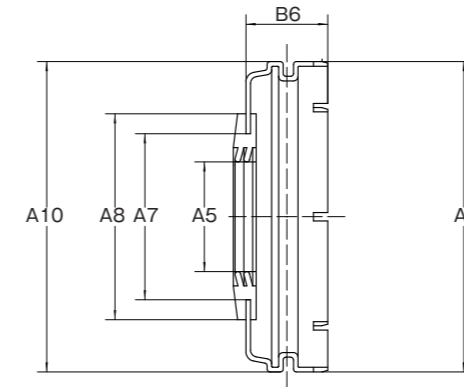

名称:Cカバー
型式:SSUC***-C

標準仕様
Standard Specification

カバー Cover	ステンレスSUS304(相当) Stainless (equivalent)
シール Seals	ニトリルゴム Nitrile Rubber

RoHS 10

軸径 Shaft Dia (mm)	型番 Number	主要寸法(mm) Main Dimensions (mm)						軸受型番 Bearing Number	重量 (g) Weight (g) Reference
		A4	A5	A7	A8	A10	B6		
17	SSUC203-C	54.25	16.14	26	33	54	14.3	SSUC203	22
20	SSUC204-C	54.25	19.16	29	36	54	14.3	SSUC204	22
25	SSUC205-C	60.25	24.19	35	41	60	15.4	SSUC205	27
30	SSUC206-C	70.35	29.22	38.5	45	70	16.9	SSUC206	36
35	SSUC207-C	80.35	34.25	46	53	80	18.7	SSUC207	44
40	SSUC208-C	88.22	39.28	49.5	56	88	22.9	SSUC208	54
45	SSUC209-C	95.22	44.31	54.5	61	95	22.9	SSUC209	66
50	SSUC210-C	100.1	49.34	62.5	69	100	25.8	SSUC210	81

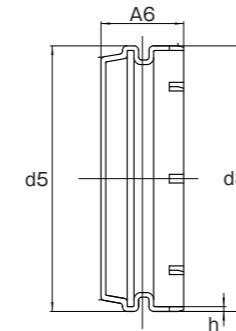

名称:Dカバー
型式:SSUC***-D

標準仕様
Standard Specification

カバー Cover	ステンレスSUS304(相当) Stainless (equivalent)
--------------	--

RoHS 10

軸径 Shaft Dia (mm)	型番 Number	主要寸法(mm) Main Dimensions (mm)				軸受型番 Bearing Number	重量 (g) Weight (g) Reference
		d3	d5	A6	h		
17	SSUC203-D	54.25	54	14.3	0.8	SSUC203	23
20	SSUC204-D	54.25	54	14.3	0.8	SSUC204	23
25	SSUC205-D	60.25	60	15.4	0.8	SSUC205	30
30	SSUC206-D	70.35	70	16.9	0.8	SSUC206	39
35	SSUC207-D	80.35	80	18.7	0.8	SSUC207	50
40	SSUC208-D	88.22	88	22.9	0.8	SSUC208	64
45	SSUC209-D	95.22	95	22.9	0.8	SSUC209	82
50	SSUC210-D	100.1	100	25.8	1.0	SSUC210	105

インサート軸受 (軽量型)

INSERT BEARINGS (LIGHT)

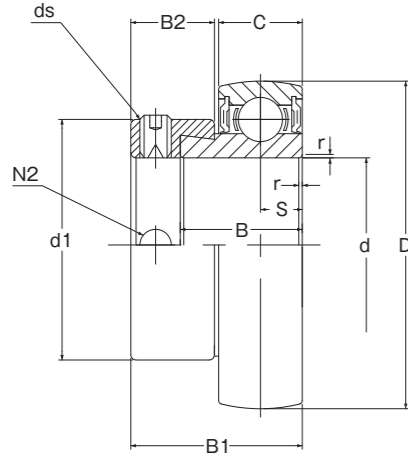
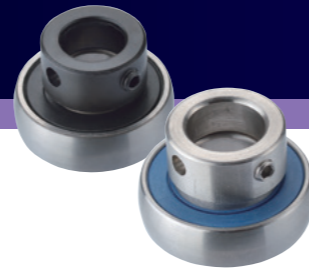

標準仕様 Standard Specification

軸受 Bearing	U形	SUJ2(相当) (equivalent)
	SU形	SUS440C(相当) (equivalent)
潤滑油 Lubricant	U形	リチウム系グリース Lithium Greases
	SU形	H1 認証食品用グリース H1 Certificated Grease For Food
耐熱温度 Heat-Resistant Temperature	U形	110℃(参考値)
	SU形	120℃(参考値)

RoHS 10

軽量形ベアリングユニット用 (偏心カラータイプ) (U形) LIGHT BEARING UNITS (ECCENTRIC COLLAR TYPE) (U)

軸径 Shaft Dia (mm)	型番 Number	主要寸法(mm) Main Dimensions (mm)											基本定格荷重 Basic Load Rating		重量 (kg) Weight (Kg) Reference
		d	D	B1	B	C	r	S	d1	B2	ds	N2	Cr(N)	Cor(N)	
10	U000	10	26	17.5	11	8	0.7	4	17	8.5	M4×0.7	3.3	4600	1960	0.03
12	U001	12	28	17.5	11	8	0.7	4	19	8.5	M4×0.7	3.3	5580	2840	0.03
15	U002	15	32	18.5	12	9	0.7	4.5	22	8.5	M4×0.7	3.3	5580	2840	0.04
17	U003	17	35	20.5	13.5	10	0.8	5	25	9.5	M4×0.7	3.3	5970	3280	0.06
20	U004	20	42	24.5	16.5	12	1.3	6	30	11	M5×0.8	4.2	9350	5040	0.10
25	U005	25	47	25.5	17.5	12	1.3	6.0	36	12	M5×0.8	4.2	10100	5600	0.12
30	U006	30	55	26.5	18.5	13	1.5	6.5	42	12	M5×0.8	4.2	13200	8000	0.17

軽量形ステンレス ベアリングユニット用 (偏心カラータイプ) (SU形) LIGHT STAINLESS BEARING UNITS (ECCENTRIC COLLAR TYPE) (SU)

軸径 Shaft Dia (mm)	型番 Number	主要寸法(mm) Main Dimensions (mm)											基本定格荷重 Basic Load Rating		重量 (kg) Weight (Kg) Reference
		d	D	B1	B	C	r	S	d1	B2	ds	N2	Cr(N)	Cor(N)	
10	SU000	10	26	17.5	11	8	0.7	4	17	8.5	M4×0.7	3.3	4600	1960	0.03
12	SU001	12	28	17.5	11	8	0.7	4	19	8.5	M4×0.7	3.3	5580	2840	0.03
15	SU002	15	32	18.5	12	9	0.7	4.5	22	8.5	M4×0.7	3.3	5580	2840	0.04
17	SU003	17	35	20.5	13.5	10	0.8	5	25	9.5	M4×0.7	3.3	5970	3280	0.06
20	SU004	20	42	24.5	16.5	12	1.3	6	30	11	M5×0.8	4.2	9350	5040	0.10
25	SU005	25	47	25.5	17.5	12	1.3	6	36	12	M5×0.8	4.2	10100	5600	0.12
30	SU006	30	55	26.5	18.5	13	1.5	6.5	42	12	M5×0.8	4.2	13200	8000	0.17

Cr=基本動定格荷重 Cor=基本静定格荷重
Cr=Basic dynamic rated load Cor=Basic static rated load

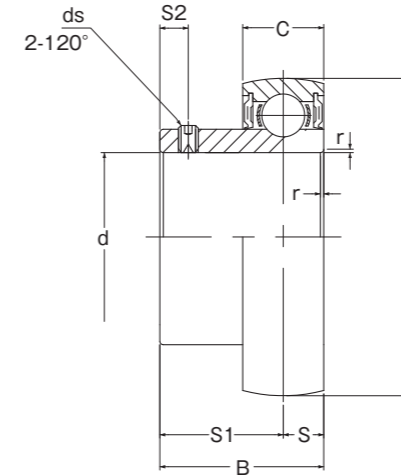

標準仕様 Standard Specification

軸受 Bearing	K形	SUJ2(相当) (equivalent)
	SK形	SUS440C(相当) (equivalent)
潤滑油 Lubricant	K形	リチウム系グリース Lithium Greases
	SK形	H1 認証食品用グリース H1 Certificated Grease For Food
耐熱温度 Heat-Resistant Temperature	K形	110℃(参考値)
	SK形	120℃(参考値)

RoHS 10

軽量形ベアリングユニット用 (止めねじタイプ) (K形) LIGHT BEARING UNITS (Set Screw Type) (K)

軸径 Shaft Dia (mm)	型番 Number	主要寸法(mm) Main Dimensions (mm)										基本定格荷重 Basic Load Rating		重量 (kg) Weight (Kg) Reference
		d	D	B	C	r	S	S1	S2	ds	Cr(N)	Cor(N)		
10	K000	10	26	14	8	0.7	4	10	3	M3×0.35	4600	1960	0.02	
12	K001	12	28	14.5	8	0.7	4	10.5	3	M3×0.35	5090	2400	0.03	
15	K002	15	32	16.5	9	0.7	4.5	12	3.5	M4×0.5	5580	2840	0.04	
17	K003	17	35	17.5	10	0.8	5	12.5	3.5	M4×0.5	5970	3280	0.05	
20	K004	20	42	21	12	1.3	6	15	4	M5×0.5	9350	5040	0.08	
25	K005	25	47	22.5	12	1.3	6	16.5	4.5	M5×0.5	10100	5600	0.10	
30	K006	30	55	24.5	13	1.5	6.5	18	5.0	M5×0.5	13200	8000	0.15	

軽量形ステンレス ベアリングユニット用 (止めねじタイプ) (SK形) LIGHT STAINLESS BEARING UNITS (Set Screw Type) (SK)

軸径 Shaft Dia (mm)	型番 Number	主要寸法(mm) Main Dimensions (mm)										基本定格荷重 Basic Load Rating		重量 (kg) Weight (Kg) Reference
		d	D	B	C	r	S	S1	S2	ds	Cr(N)	Cor(N)		
10	SK000	10	26	14	8	0.7	4	10	3	M3×0.5	4600	1960	0.02	
12	SK001	12	28	14.5	8	0.7	4	10.5	3	M3×0.5	5090	2400	0.03	
15	SK002	15	32	16.5	9	0.7	4.5	12	3.5	M4×0.7	5580	2840	0.04	
17	SK003	17	35	17.5	10	0.8	5	12.5	3.5	M4×0.7	5970	3280	0.05	
20	SK004	20	42	21	12	1.3	6	15	4	M5×0.8	9350	5040	0.08	
25	SK005	25	47	22.5	12	1.3	6	16.5	4.5	M5×0.8	10100	5600	0.10	
30	SK006	30	55	24.5	13	1.5	6.5	18	5.0	M5×0.8	13200	8000	0.15	

Cr=基本動定格荷重 Cor=基本静定格荷重
Cr=Basic dynamic rated load Cor=Basic static rated load

コンパクトベアリングユニット

COMPACT BEARING UNITS

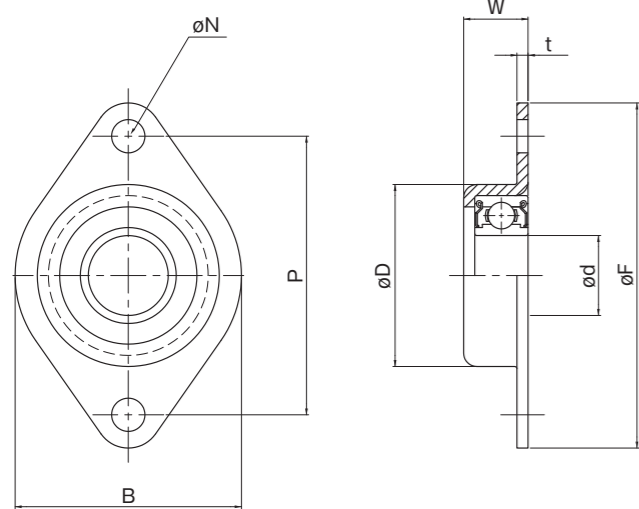

標準仕様

Standard Specification

軸受 Bearing	スチール Steel	SUJ2(相当) (equivalent)
	ステンレス Stainless	SUS440C(相当) (equivalent)
ハウジング Housing	スチール Steel	SPCC(相当)四三酸化鉄皮膜 (equivalent) Alkaline Blackening
	ステンレス Stainless	SUS304(相当) (equivalent)
潤滑油 Lubricant	スチール Steel	リチウム系グリース Lithium Greases
	ステンレス Stainless	リチウム系グリース Lithium Greases
耐熱温度 Heat-Resistant Temperature	スチール Steel	110°C(参考値)
	ステンレス Stainless	120°C(参考値)

RoHS 10

スチールタイプ STEEL TYPE

軸径 Shaft Dia	型番 Unit Number	使用軸受 Use Bearing	主要寸法(mm) Main Dimensions(mm)							重量 (kg) Weight (Kg) Reference
			B	t	W	P	F	D	N	
8	CU-608	608ZZ	32	1.2	8.2	34	42	24.4	4.5	0.02
10	CU-6000	6000ZZ	36	1.2	9.2	38	46	28.4	4.5	0.03
10	CU-6200	6200ZZ	40	1.2	10.2	42	50	32.4	4.5	0.04
12	CU-6201	6201ZZ	45	1.4	11.4	48	58	34.8	5.5	0.06
15	CU-6002	6002ZZ	45	1.4	11.4	48	58	34.8	5.5	0.06
10	CU-6000-2RS	6000-2RS	36	1.2	9.2	38	46	28.4	4.5	0.03
10	CU-6200-2RS	6200-2RS	40	1.2	10.2	42	50	32.4	4.5	0.04
12	CU-6201-2RS	6201-2RS	45	1.4	11.4	48	58	34.8	5.5	0.06
15	CU-6002-2RS	6002-2RS	45	1.4	11.4	48	58	34.8	5.5	0.06

ステンレスタイプ STAINLESS TYPE

軸径 Shaft Dia	型番 Unit Number	使用軸受 Use Bearing	主要寸法(mm) Main Dimensions(mm)							重量 (kg) Weight (Kg) Reference
			B	t	W	P	F	D	N	
8	SSCU-608	SS608ZZ	32	1.0	8.0	34	42	24.0	4.5	0.02
10	SSCU-6000	SS6000ZZ	36	1.0	9.0	38	46	28.0	4.5	0.03
10	SSCU-6200	SS6200ZZ	40	1.0	10.0	42	50	32.0	4.5	0.04
12	SSCU-6201	SS6201ZZ	45	1.5	11.5	48	58	35.0	5.5	0.06
15	SSCU-6002	SS6002ZZ	45	1.5	11.5	48	58	35.0	5.5	0.06
10	SSCU-6000-2RS	SS6000-2RS	36	1.0	9.0	38	46	28.0	4.5	0.03
10	SSCU-6200-2RS	SS6200-2RS	40	1.0	10.0	42	50	32.0	4.5	0.04
12	SSCU-6201-2RS	SS6201-2RS	45	1.5	11.5	48	58	35.0	5.5	0.06
15	SSCU-6002-2RS	SS6002-2RS	45	1.5	11.5	48	58	35.0	5.5	0.06

Cr=基本動定格荷重 Cor=基本静定格荷重
Cr=Basic dynamic rated load Cor=Basic static rated load

止めねじ付きベアリング

BALL BEARINGS SET SCREW TYPE

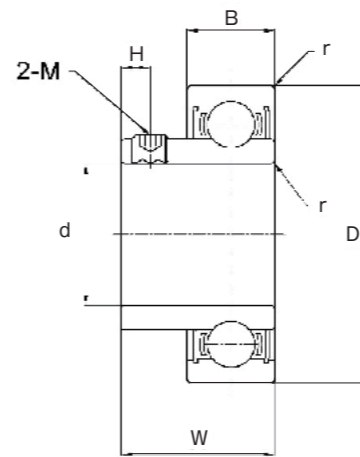

標準仕様

Standard Specification

内外輪 Inner and Outer Rings	SUS420J2(相当) (equivalent)
ボール Ball	SUS420J2(相当) (equivalent)
保持器 Cage	SUS304(相当) (equivalent)
シールド Shields	SUS304(相当) (equivalent)
潤滑油 Lubricant	H1 認証食品用グリース H1 Certificated Grease For Food
精度等級 Accuracy Class	JIS 0級 JIS 0 Class
すきま Clearance	CN CN Clearance

RoHS 10

型式 Unit Number	主要寸法(mm) Main Dimensions(mm)								基本定格荷重 Basic Load Rating		許容回転数 (rpm) (参考) Allowable Maximum Speed(rpm)	重量 (g) Weight (g) Reference
	d		D	W	B	H	M	r	Cr(kN)	Cor(kN)		
	d寸法	寸法差										
SUR6900ZZ	10		22	13	6	3.0	M3×0.5	0.30	2.70	1.27	9100	13
SUR6000ZZ			26	15	8	3.0	M3×0.5	0.30	4.55	1.96	7800	24
SUR6200ZZ			30	17	9	3.5	M4×0.7	0.60	5.10	2.39	6800	41
SUR6901ZZ	12	+0.015 0	24	13	6	3.0	M3×0.5	0.30	2.89	1.46	5200	15
SUR6001ZZ			28	15	8	3.0	M3×0.5	0.30	5.10	2.39	7800	27
SUR6201ZZ			32	19	10	3.5	M4×0.7	0.60	6.80	3.05	7500	47
SUR6902ZZ	15		28	14	7	3.0	M3×0.5	0.30	4.30	2.25	6500	22
SUR6002ZZ			32	17	9	3.0	M3×0.5	0.30	5.60	2.84	4500	40
SUR6202ZZ			35	20	11	3.5	M4×0.7	0.60	7.65	3.75	6000	59
SUR6904ZZ	20	+0.018 0	37	18	9	3.5	M4×0.7	0.30	6.40	3.70	9100	51
SUR6004ZZ			42	21	12	4.5	M5×0.8	0.60	9.40	5.05	7500	87
SUR6204ZZ			47	23	14	4.5	M5×0.8	1.00	12.80	6.65	5800	132

Cr=基本動定格荷重 Cor=基本静定格荷重
Cr=Basic dynamic rated load Cor=Basic static rated load
※上記の止めねじ付きベアリングの内径精度は、JIS B 1558の規格に準じています。

オイルスブッシュ(オイルスベアリング)

OILLESS BUSHES (OILLESS BEARINGS)



高力黄銅系・固体潤滑剤埋込軸受

HIGH-STRENGTH BRASS OILLESS BEARINGS

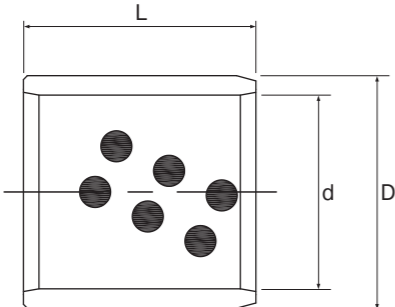

RoHS 10 鉛フリー

標準仕様
Standard Specification

材質 Material	CAC304(相当) (equivalent)
内径公差 Inner Tolerance	F7
外径公差 Outer Tolerance	m6
耐熱温度 Heat-Resistant Temperature	300℃(参考値)

推奨相手軸公差
Recommend Shaft Tolerance

一般用(高負荷) General(Heavy Load)	d8
一般用(軽負荷) General(Light Load)	e7
高精度用 High Precision	f7

推奨相手ハウジング公差：H7
Recommend Housing Tolerance

内径 Inner		外径 Outer		長さ公差 ^{-0.1 -0.3} Length	型番 Bearing Number	重量 (g) Weight (g) Reference
d	公差 Tolerance	D	公差 Tolerance			
6	+0.022 +0.010	10	+0.015 +0.006	8	JDB-061008	3
				10	JDB-061010	3
				12	JDB-061012	3
				15	JDB-061015	4
8	+0.028 +0.013	12	+0.018 +0.007	8	JDB-081208	3
				10	JDB-081210	4
				12	JDB-081212	5
10	+0.028 +0.013	14	+0.018 +0.007	8	JDB-101408	4
				10	JDB-101410	4
				12	JDB-101412	6
				15	JDB-101415	7
				20	JDB-101420	10
12	+0.034 +0.016	18	+0.018 +0.007	8	JDB-121808	7
				10	JDB-121810	8
				12	JDB-121812	10
				15	JDB-121815	13
				16	JDB-121816	14
				19	JDB-121819	16
				20	JDB-121820	17
				25	JDB-121825	21
13	+0.034 +0.016	19	+0.021 +0.008	10	JDB-131910	9
				12	JDB-131912	11
				15	JDB-131915	14
				20	JDB-131920	18
				25	JDB-131925	24
30	JDB-131930	28				

内径 Inner		外径 Outer		長さ公差 ^{-0.1 -0.3} Length	型番 Bearing Number	重量 (g) Weight (g) Reference
d	公差 Tolerance	D	公差 Tolerance			
14	+0.034 +0.016	20	+0.021 +0.008	10	JDB-142010	10
				12	JDB-142012	12
				15	JDB-142015	15
				16	JDB-142016	16
				20	JDB-142020	21
15	+0.034 +0.016	21	+0.021 +0.008	25	JDB-142025	26
				30	JDB-142030	31
				10	JDB-152110	10
				12	JDB-152112	13
15	+0.034 +0.016	21	+0.021 +0.008	15	JDB-152115	15
				16	JDB-152116	17
				20	JDB-152120	21
				25	JDB-152125	26
				30	JDB-152130	31
				35	JDB-152135	37
				40	JDB-152140	42
16	+0.034 +0.016	22	+0.021 +0.008	10	JDB-162210	11
				12	JDB-162212	13
				15	JDB-162215	16
				16	JDB-162216	17
				19	JDB-162219	21
				20	JDB-162220	22
				25	JDB-162225	27
				30	JDB-162230	32
				35	JDB-162235	38
				40	JDB-162240	43

*上記型番以外も製造可能です。お気軽にお問い合わせください。
*We can also produce bearings not in the list. Please contact us.

内径 Inner		外径 Outer		長さ公差 ^{-0.1 -0.3} Length	型番 Bearing Number	重量 (g) Weight (g) Reference
d	公差 Tolerance	D	公差 Tolerance			
18	+0.034 +0.016	24	+0.021 +0.008	10	JDB-182410	12
				12	JDB-182412	15
				15	JDB-182415	18
				16	JDB-182416	19
				20	JDB-182420	25
				25	JDB-182425	31
				30	JDB-182430	36
				35	JDB-182435	42
				40	JDB-182440	48
20	+0.041 +0.020	28	+0.021 +0.008	10	JDB-202810	18
				12	JDB-202812	22
				15	JDB-202815	28
				16	JDB-202816	30
				19	JDB-202819	35
				20	JDB-202820	38
				25	JDB-202825	48
				30	JDB-202830	57
				35	JDB-202835	67
				40	JDB-202840	76
				50	JDB-202850	95
				10	JDB-203010	24
				12	JDB-203012	29
				15	JDB-203015	36
				16	JDB-203016	39
				20	JDB-203020	49
				25	JDB-203025	63
30	JDB-203030	75				
35	JDB-203035	89				
40	JDB-203040	100				
50	JDB-203050	125				
25	+0.041 +0.020	33	+0.025 +0.009	12	JDB-253312	26
				15	JDB-253315	31
				16	JDB-253316	34
				20	JDB-253320	42
				25	JDB-253325	53
				30	JDB-253330	65
				35	JDB-253335	75
				40	JDB-253340	87
				50	JDB-253350	109
				60	JDB-253360	127
				12	JDB-253512	34
				15	JDB-253515	42
				16	JDB-253516	45
				20	JDB-253520	56
				25	JDB-253525	70
				30	JDB-253530	85
				35	JDB-253535	99
40	JDB-253540	115				
50	JDB-253550	142				
60	JDB-253560	163				

*上記型番以外も製造可能です。お気軽にお問い合わせください。
*We can also produce bearings not in the list. Please contact us.

内径 Inner		外径 Outer		長さ公差 ^{-0.1 -0.3} Length	型番 Bearing Number	重量 (g) Weight (g) Reference
d	公差 Tolerance	D	公差 Tolerance			
30	+0.041 +0.020	38	+0.025 +0.009	12	JDB-303812	29
				15	JDB-303815	37
				20	JDB-303820	50
				25	JDB-303825	62
				30	JDB-303830	74
				35	JDB-303835	86
				40	JDB-303840	99
				50	JDB-303850	126
				60	JDB-303860	153
				12	JDB-304012	39
30	+0.041 +0.020	40	+0.025 +0.009	15	JDB-304015	50
				20	JDB-304020	62
				25	JDB-304025	83
				30	JDB-304030	100
				35	JDB-304035	114
				40	JDB-304040	129
				50	JDB-304050	168
				60	JDB-304060	201
				20	JDB-354420	69
				25	JDB-354425	85
35	+0.050 +0.025	44	+0.025 +0.009	30	JDB-354430	102
				35	JDB-354435	119
				40	JDB-354440	137
				50	JDB-354450	171
40	+0.050 +0.025	50	+0.025 +0.009	20	JDB-405020	86
				25	JDB-405025	103
				30	JDB-405030	133
				35	JDB-405035	153
				40	JDB-405040	174
				50	JDB-405050	213
				60	JDB-405060	261
				70	JDB-405070	300
				80	JDB-405080	338
				30	JDB-506030	156
50	+0.050 +0.025	60	+0.030 +0.011	35	JDB-506035	180
				40	JDB-506040	204
				50	JDB-506050	262
				60	JDB-506060	310
				70	JDB-506070	358
				80	JDB-506080	412

技術資料

TECHNICAL SPECIFICATIONS

高炭素クロム軸受鋼及びステンレス鋼及び炭素鋼の化学成分

CHEMICAL COMPOSITION OF HIGH-CARBON CHROMIUM BEARING STEEL AND STAINLESS STEEL

規格 Standard	記号 Symbol	化学成分(%) Chemical Composition(%)						
		C	Si	Mn	P	S	Cr	Mo
JIS GB	SUJ2 GCr15	0.95~1.10	0.15~0.35	≤0.5	≤0.025	≤0.025	1.30~1.60	≤0.08
		0.95~1.05	0.15~0.35	0.25~0.45	≤0.025	≤0.025	1.40~1.65	≤0.08
JIS GB	SUS440C 95Cr18	0.95~1.10	≤1.00	≤1.00	≤0.040	≤0.030	16.00~18.00	≤0.75
		0.95~1.00	≤0.80	≤0.80	≤0.040	≤0.030	17.00~19.00	—
JIS GB	S20C 20	0.18~0.23	0.15~0.35	0.30~0.60	≤0.030	≤0.030	≤0.20	—
		0.17~0.24	0.17~0.57	0.35~0.65	≤0.035	≤0.035	≤0.25	—

深溝玉軸受のラジアル内部すきま

CLEARANCE

単位(Units)/μm

呼び軸受 内径 Nominal Bore Diameter d(mm)	単位(Units)/μm										
	C2		CN		C3		C4		C5		
	を 超え Over	以下 Incl	最小 Min	最大 Max	最小 Min	最大 Max	最小 Min	最大 Max	最小 Min	最大 Max	
2.5 6 10	6 10 18	0 0 0	7 7 9	2 2 3	13 13 18	8 8 11	23 23 25	— — 18	— — 33	— — 25	— — 45
18 24 30	24 30 40	0 1 1	10 11 11	5 5 6	20 20 20	13 13 15	28 28 33	20 23 28	36 41 46	28 30 40	48 53 64
40 50 65	50 65 80	1 1 1	11 15 15	6 8 10	23 28 30	18 23 25	36 43 51	30 38 46	51 61 71	45 55 65	73 90 105

※KMT標準すきまCN

電動機用深溝玉軸受のラジアル内部すきま

CLEARANCE

単位(Units)/μm

呼び軸受内径 Nominal Bore Diameter d(mm)	CM			
	を 超え Over	以下 Incl	最小 Min	最大 Max
	10(を含む) 18 30 50	18 30 50 80	4 5 9 12	11 12 17 22

ミニチュア・小径玉軸受のラジアル内部すきま

CLEARANCE

単位(Units)/μm

すきま記号	単位(Units)/μm											
	MC1		MC2		MC3		MC4		MC5		MC6	
	最小 Min	最大 Max	最小 Min	最大 Max	最小 Min	最大 Max	最小 Min	最大 Max	最小 Min	最大 Max	最小 Min	最大 Max
すきま	0	5	3	8	5	10	8	13	13	20	20	28

備考 1.標準的なすきまはMC3である
2.ミニチュア玉軸受は、外径が9mm未満
3.小径玉軸受は、外径が9mm以上で軸受内径が10mm未満

ゴムシール型番対照表

RUBBER SEAL PART NUMBER COMPARISON TABLE

メーカー Manufacturer	接触ゴムシール Contact Rubber Seals	非接触ゴムシール Contactless Rubber Seals
KMT	2RS	2RZ
NSK	DD・DDU	VV
NTN	LLU	LLB
NACHI	2NSE	2NKE
KOYO	2RS	2RU

※接触シール形(2RS)の接触量は各社異なります。
Different companies have differences on the quantity of contact (2RS).

材料特性(参考値)

MATERIAL LIST(REFERANCE)

項目 Topic	ジルコニア ZrO ₂	窒化ケイ素 Si ₃ N ₄	炭化ケイ素 SiC	高炭素クロム軸受鋼 SUJ2	ステンレス軸受鋼 SUS440C	アルミナ Al ₂ O ₃	ステンレス鋼 SUS304	
密度 Density	g/cm ³	6.0	3.2	3.2	7.8	7.9	3.92	8.0
熱膨張係数 Thermal Expansion Coefficient	×10 ⁻⁶ /°C	10.5	3.2	4.3	11	17	8.2	16
縦弾性係数 Vertical Elastic Coefficient	Gpa	210	320	380	208	200	360	193
硬度 Hardness	HV	1300	1700	2350~2450	800	700	1800	170
耐熱温度 Heat-resistant Temperature	°C	400	800	1100	120	150	400	150
磁性 Magnetism	非磁性 Nonmagnetic	非磁性 Nonmagnetic	非磁性 Nonmagnetic	強磁性 Ferromagnetic	強磁性 Ferromagnetic	非磁性 Nonmagnetic	微磁性 Mildly Ferromagnetic	
特性 Characteristics	高耐食性 低コスト High Corrosion Esistence Low Cost	耐摩耗性 耐食性 耐腐食性 Corrosion-resistance	高耐熱性 高耐食性 耐熱耐食性 Thermal Wear High Corrosion Resistance	—	—	耐摩耗性 高耐食性 耐腐食性 Wear Resistance High Corrosion Resistance	—	

素材組み合わせ特性表(参考値)

COMBINATION CHARACTRISTIC LIST(REFERANCE)

内外輪 Inner And Outer Ring	ボール Ball	保持器 Cage	耐熱温度 Heat-Resistant Temperature	耐腐食性 Corrosion Resistance	耐荷重性 Load Resistance	回転性能 Rotary Performance
ジルコニア ZrO ₂	ジルコニア ZrO ₂	PTFE	180°C	○	△	△
ジルコニア ZrO ₂	ジルコニア ZrO ₂	PEEK	260°C	○	△	△
ジルコニア ZrO ₂	ジルコニア ZrO ₂	無し	400°C	○	△	△
窒化ケイ素 Si ₃ N ₄	窒化ケイ素 Si ₃ N ₄	PTFE	180°C	○	○	○
窒化ケイ素 Si ₃ N ₄	窒化ケイ素 Si ₃ N ₄	PEEK	260°C	○	○	○
窒化ケイ素 Si ₃ N ₄	窒化ケイ素 Si ₃ N ₄	無し	800°C	○	○	○
ジルコニア ZrO ₂	窒化ケイ素 Si ₃ N ₄	PTFE	180°C	○	△	○
ジルコニア ZrO ₂	窒化ケイ素 Si ₃ N ₄	PEEK	260°C	○	△	○
ジルコニア ZrO ₂	窒化ケイ素 Si ₃ N ₄	無し	400°C	○	△	○
炭化ケイ素 SiC	炭化ケイ素 SiC	PTFE	180°C	◎	△	△
炭化ケイ素 SiC	炭化ケイ素 SiC	PEEK	260°C	◎	△	△
炭化ケイ素 SiC	炭化ケイ素 SiC	無し	1100°C	◎	△	△
ステンレス軸受鋼 SUS440C	ステンレス軸受鋼 SUS440C	SUS304	150°C	△	◎	◎
高炭素クロム軸受鋼 SUJ2	高炭素クロム軸受鋼 SUJ2	SPCC	120°C	×	◎	◎
アルミナ Al ₂ O ₃	アルミナ Al ₂ O ₃	PTFE	180°C	○	△	△
アルミナ Al ₂ O ₃	アルミナ Al ₂ O ₃	PEEK	260°C	○	△	△
アルミナ Al ₂ O ₃	アルミナ Al ₂ O ₃	無し	400°C	○	△	△
SUS440C SUS440C	Si ₃ N ₄ Si ₃ N ₄	SUS304	150°C	△	◎	◎

技術資料

TECHNICAL SPECIFICATIONS

樹脂材料特性(参考値)

MATERIAL LIST (REFERENCE)

項目 Topic	フッ素系 (テフロン) PTFE	ポリエーテル エテルケトン PEEK	ポリ アセタール POM	ポリプロ ピレン PP	ポリアミド PA66
耐熱温度 Heat-resistant Temperature	℃ 180	260	110	100	100
密度 Density	g/cm ³ 2.18	1.32	1.42	0.91	1.14
引張強度 tensile strength	kgf/cm ² 140~350	1000	620	280	850
伸び比率 Flexural Strength Rate	% 200~400	20	40	200~700	60
曲げ強度 Bending Strength	kgf/cm ² 180	1730	910	420~560	970
熱膨張係数 Thermal Expansion Coefficient	×10 ⁻⁵ /℃ 5	5	9	11	9
吸水率 Water Absorption	% 0.01	0.5	0.22	0.03	0.6

セラミック耐食性(参考値)

CORROSION RESISTANCE OF CERAMIC (REFERENCE)

薬液 Liquid chemical	ジルコニア ZrO ₂	窒化ケイ素 Si ₃ N ₄	炭化ケイ素 SiC
塩酸 Hydrochloric acid	○	△	○
硝酸 Nitric acid	○	△	○
硫酸 Sulfuric acid	○	○	○
りん酸 Phosphoric acid	△	△	○
ふっ酸 Hydrofluoric acid	×	△	○
水酸化ナトリウム Sodium hydroxide	△	△	○
水酸化カリウム Potassium hydroxide	△	△	△
炭酸ナトリウム Sodium carbonate	△	△	△
硝酸ナトリウム Sodium nitrate	△	△	△
海水 Seawater	◎	◎	◎

注)薬液の濃度、温度により条件は異なります。

ベアリングユニットの精度

ベアリングユニット精度は、JISB 1558(転がり軸受-インサート軸受)及びJISB 1559(転がり軸受-インサート軸受箱)の規格に準じています。

PRECISION OF BEARING UNITS

Bearing units precision follows a standard of JISB 1558(Rolling bearings-insert bearings) and JISB 1559(Rolling bearings-insert bearings)

内輪の許容値及び許容差

TOLERANCE AND ALLOWANCE LIMIT FOR INNER RING

単位(Units)/μm

呼び軸受内径 Nominal Bore Diameter d(mm)	平面内平均内径の寸法差 Deviation Of Mean Bore Diameter In A Single Plane Δdmp		平面内内径不同 Variation Of Bore Diameter In A Single Plane Vdsp		内輪の偏心面の 偏心量の寸法差 Deviation Of Eccentricity Of Eccentric Face Of Inner Ring ΔHs		内輪幅の寸法差 Deviation Of A Single Inner Ring Width ΔBs		内輪のラジアルの振れ Radial Runout Of Inner Ring Of Assembled Bearing Kia	
	を 超え Over	以下 Incl	上 High	下 Low	最大 Max	上 High	下 Low	上 High	下 Low	最大 Max
10	18		+15	0	10	+100	-100	0	-120	15
18	31.75		+18	0	12	+100	-100	0	-120	18
31.75	50.8		+21	0	14	+100	-100	0	-120	20
50.8	80		+24	0	16	+100	-100	0	-150	25
80	120		+28	0	19	+100	-100	0	-200	30
120	180		+33	0	22	+100	-100	0	-250	35

潤滑油

GREASE

メーカー Manufacturer	銘柄 Brand	増ちょう剤 Thickener	基油 Base oil	基油動粘度 40℃ Basis oil motion viscosity	ちよう度 Consistency	使用温度 ℃ Use temperature	特性 Characteristic
協同油脂 Kyodo Yushi	マルテンブ SR-L	リチウム	合成炭化水素油	26.0(mm ² /s)	250	-50~150	広温度範囲万能グリース (KMTベアリング標準グリース)
	マルテンブ SB-F	シウレア	合成炭化水素油	47.6(mm ² /s)	260	-40~200	高温用長寿命グリース
	マルテンブ SB-M	シウレア	合成炭化水素油	47.6(mm ² /s)	220	-40~200	高温用グリース ケミカルアタック対応
	マルテンブSL-F-1	リチウム	合成炭化水素油	17(mm ² /s)	325	-60~130	低温度下用グリース
	マルテンブSL-F-2	リチウム	合成炭化水素油	17(mm ² /s)	280	-60~130	低温度下用グリース
	マルテンブ ET-100K	シウレア	エーテル系合成油	12.8(mm ² /s)	280	-40~200	高温用長寿命グリース
	マルテンブ PS-1 (2)	リチウム	合成炭化水素油	15.9(mm ² /s)	320(275)	-50~130	低温度下用グリース
	マルテンブ LRL NO3	リチウム	エステル系合成油	—	235	-50~150	高温用長寿命グリース
昭和シェル石油 Showa Shell Sekiyu	アルバニア S2	リチウム	鉱油	131(mm ² /s)	283	-25~120	工業用万能グリース (KMTベアリングユニット標準グリース)
	アルバニア S3	リチウム	鉱油	131(mm ² /s)	242	-50~150	工業用万能グリース (KMTベアリングユニット標準グリース)
TOTAL	NEVASTANE XS80	カルシウム スルホネート	合成油	80(mm ² /s)	280	-55~180	NSF-H1 食品用グリース (KMTステンレス ベアリングユニット標準グリース)
ダイキン Daikin	デムナム L200	PTFE	フッ素油	200(mm ² /s)	280	-60~250	高温用グリース
THK	AFE-CA	シウレア	合成油	99(mm ² /s)	280	-40~180	低発塵クリーングリース

外輪の許容差及び許容値

TOLERANCE AND ALLOWANCE LIMIT FOR OUTER RING

単位(Units)/μm

呼び軸受外径 Nominal Outside Diameter D(mm)	平均外径の寸法差 Deviation Of Mean Outside Diameter ΔDm		外輪のラジアル振れ Radial Runout Of Outside Ring Of Assembled Bearing Kea		
	を 超え Over	以下 Incl	上 High	下 Low	最大 Max
18	30		0	-9	15
30	50		0	-11	20
50	80		0	-13	25
80	120		0	-15	35
120	150		0	-18	40
150	180		0	-25	45
180	250		0	-30	50
250	315		0	-35	60

軸受箱の球状軸受座直径の許容値

TOLERANCE OF HOUSINGS

単位(Units)/μm

球状軸受座の 呼び直径 Nominal Diameter Of Spherical Bearing Seating Da(mm)	球状軸受座の平面内平均内径の寸法差 Deviation Of Mean Bore Diameter In A Single Plane Of Spherical Bearing Seating ΔDam						
	公差域クラス H7 Tolerance Range Class		公差域クラス J7 Tolerance Range Class		公差域クラス K7 Tolerance Range Class		
を 超え Over	以下 Incl	上 High	下 Low	上 High	下 Low	上 High	下 Low
18	30	+21	0	+12	-9	+6	-15
30	50	+25	0	+14	-11	+7	-18
50	80	+30	0	+18	-12	+9	-21
80	120	+35	0	+22	-13	+10	-25
120	180	+40	0	+26	-14	+12	-28
180	250	+46	0	+30	-16	+13	-33
250	315	+52	0	+36	-16	+16	-36

備考)KMTではJ7を採用。 Note)KMT basically use J7.

ミニチュア/小径玉軸受型番対照表

MINIATURE/SMALL BALL BEARING PART NUMBER COMPARISON TABLE

内径 Inner	KMT	NMB	NTN	NSK
3	MR63ZZ	L-630ZZ	WA673SSA	MR63ZZ
	683ZZ	L-730ZZ	W683ZZA	683AZZ
	693ZZ	R-830ZZ	W693ZZ	693ZZ
	MR93ZZ	R-930ZZY04	WBC3-9ZZA	MR93ZZ
	603ZZ	R-930ZZ	W603ZZ	603ZZ
	623ZZ	R-1030ZZ	623ZZ	623ZZ
4	MR74ZZ	L-740ZZ	WA674ASSA	MR74ZZ
	MR84ZZ	L-840ZZ	WBC4-8ZZ	MR84ZZ
	684ZZ	L-940ZZ	W684AX50ZZ	684AZZ
	MR104ZZ	L-1040X2ZZ	WBC4-10ZZ	MR104BZZ
	694ZZ	R-1140ZZ	694ZZ	694ZZ
	604ZZ	R-1240KK1	604ZZ	604ZZ
	624ZZ	R-1340HH	624ZZ	624ZZ
	634ZZ	R-1640HH	634ZZ	634ZZ1
5	MR85ZZ	L-850ZZ	WA675ZZ	MR85ZZ
	MR95ZZ	L-950ZZ	WBC5-9ZZ	MR95ZZ1
	MR105ZZ	L-1050ZZ	WBC5-10ZZ	MR105ZZ
	MR115ZZ	L-1150ZZY04	WBC5-11ZZ	MR115ZZ
	685ZZ	L-1150ZZ	W685ZZ	685ZZ
	695ZZ	R-1350ZZ	695ZZ	695ZZ
	605ZZ	R-1450ZZ	605ZZ	605ZZ
	625ZZ	R-1650HH	625ZZ	625ZZ1
	635ZZ	R-1950ZZ	635ZZ	635ZZ1
	6	MR106ZZ	L-1060ZZ	WA676AZZ
MR126ZZ		L-1260ZZ	WBC6-12ZZ	MR126ZZ
686ZZ		L-1360ZZ	W686ZZ	686AZZ
696ZZ		R-1560X13KK	696ZZ	696ZZ1
606ZZ		R-1760X2ZZ	606ZZ	606ZZ
626ZZ		R-1960ZZ	626ZZ	626ZZ1
636ZZ		—	—	636ZZ
7	MR117ZZ	L-1170ZZ	WA677ZZ	MR117ZZ
	MR137ZZ	L-1370ZZ	WBC7-13ZZ	MR137ZZ
	687ZZ	L-1470KK	W687AZZ	687ZZ1
	697ZZ	—	697ZZ	697ZZ1
	607ZZ	R-1970ZZ	607ZZ	607ZZ1
627ZZ	R-2270HH	627ZZ	627ZZ	
8	MR128ZZ	L-1280ZZ	W678AZZ	MR128ZZ1
	MR148ZZ	L-1480ZZ	WBC8-14ZZ	MR148ZZ
	688ZZ	L-1680HH	W688AZZ	688AZZ1
	698ZZ	R-1980KK	698ZZ	698ZZ
	608ZZ	R-2280HH	608ZZ	608ZZ
	628ZZ	—	628ZZ	628ZZ
9	689ZZ	L-1790ZZ	W689ZZ	689ZZ1
	699ZZ	L-2090KK	699ZZ	699ZZ1
	609ZZ	609ZZ	609ZZ	609ZZ
	629ZZ	—	629X50ZZ	629ZZ

■フランジ付 / WITH FLANGED OUTER RING

内径 Inner	KMT	NMB	NTN	NSK
3	MF63ZZ	LF-630ZZ	FLWA673SSA	MF63ZZ
	F683ZZ	LF-730ZZ	FLW683ZZA	F683AZZ
	F693ZZ	RF-830ZZ	FLW693ZZ	F693ZZ
	MF93ZZ	RF-930ZZY04	FLAWBC3-9ZZA	MF93ZZ
	F603ZZ	RF-930ZZ	FLW603ZZ	F603ZZ
	F623ZZ	RF-1030ZZ	FL623ZZ	F623ZZ
4	MF74ZZ	LF-740ZZ	FLWA674ASSA	MF74ZZ
	MF84ZZ	LF-840ZZ	FLWBC4-8ZZ	MF84ZZ
	F684ZZ	LF-940ZZ	FLW684AX50ZZ	F684ZZ
	MF104ZZ	LF-1040ZZ	FLAWBC4-10ZZ	MF104BZZ
	F694ZZ	RF-1140ZZ	FL694ZZ	F694ZZ
	F604ZZ	RF-1240ZZ	FL604ZZ	F604ZZ
	F624ZZ	RF-1340ZZ	FL624ZZ	F624ZZ
	—	—	—	—
5	MF85ZZ	LF-850ZZ	FLWA675ZZ	MF85ZZ
	MF95ZZ	LF-950ZZ	FLWBC5-9ZZ	MF95ZZ1
	MF105ZZ	LF-1050ZZ	FLAWBC5-10ZZ	MF105ZZ
	MF115ZZ	—	FLWBC5-11ZZ	—
	F685ZZ	LF-1150ZZ	FLW685ZZ	F685ZZ
	F695ZZ	RF-1350ZZ	FL695ZZ	F695ZZ
	F605ZZ	RF-1450ZZ	FL605ZZ	F605ZZ
	—	—	—	—
	—	—	—	—
	—	—	—	—
6	MF106ZZ	LF-1060ZZ	FLWA676AZZ	MF106ZZ1
	MF126ZZ	LF-1260ZZ	FLAWBC6-12ZZ	MF126ZZ
	F686ZZ	LF-1360ZZ	FLW686ZZ	F686AZZ
	F696ZZ	RF-1560ZZ	FL696ZZ	F696ZZ1
	F606ZZ	RF-1760X2ZZ	FL606ZZ	F606ZZ
	—	—	—	—
	—	—	—	—
7	F687ZZ	LF-1470ZZ	FLW687AZZ	F687ZZ1
	F697ZZ	—	FL697ZZ	F697ZZ1
	F607ZZ	RF-1970ZZ	—	F607ZZ1
	F627ZZ	RF-2270HH	—	F627ZZ
	—	—	—	—
8	MF128ZZ	LF-1280ZZ	FLAW678AZZ	MF128ZZ1
	MF148ZZ	LF-1480ZZ	FLWBC8-14ZZ	MF148ZZ
	F688ZZ	LF-1680HH	FLW688AZZ	F688AZZ
	F698ZZ	RF-1980ZZ	FL698ZZ	F698ZZ
	F608ZZ	RF-2280HH	FL608ZZ	F608ZZ
	—	—	—	—
9	F689ZZ	LF-1790ZZ	FLW689ZZ	F689ZZ1
	F699ZZ	—	—	F699ZZ1
	F609ZZ	—	—	—
—	—	—	—	

ベアリングユニット・オイルレスブッシュ型番対照表

BEARING UNIT · OILLESS BUSH PART NUMBER COMPARISON TABLE

■ベアリングユニット / BEARING UNITS

	KMT	FYH	NTN	ASAHI
ピロー形ユニット PILLOW UNITS	UCP	UCP	UCP	UCP
	UCPA	UCPA	UCUP	UCPA
ひしフランジ形ユニット RHOMBUS FLANGED UNITS	UCFL	UCFL	UCFL	UCFL
角フランジ形ユニット SQUARE FLANGED UNITS	UCF	UCF	UCF	UCF
インサート軸受 INSERT BEARINGS	UC	UC	UC	UC

■ステンレス ベアリングユニット / STAINLESS BEARING UNITS

	KMT	FYH	NTN	ASAHI
ピロー形ユニット PILLOW UNITS	SUCP	UCSP	F-UCPM	MUCP
	SUCPA	UCSPA	—	MUCPA
ひしフランジ形ユニット RHOMBUS FLANGED UNITS	SUCFL	UCSFL	F-UCFM	MUCFL
角フランジ形ユニット SQUARE FLANGED UNITS	SUCF	UCSF	—	MUCF
インサート軸受 INSERT BEARINGS	SSUC	UC-S6	—	MUC

■軽量形ベアリングユニット / LIGHT BEARING UNITS

		KMT	FYH	NTN	ASAHI
ピロー形ユニット PILLOW UNITS	偏心カラータイプ ECCENTRIC COLOR TYPE	UP	—	—	UP
	止ねじタイプ SET SCREW TYPE	KP	UP	—	KP
ひしフランジ形ユニット RHOMBUS FLANGED UNITS	偏心カラータイプ ECCENTRIC COLOR TYPE	UFL	—	—	UFL
	止ねじタイプ SET SCREW TYPE	KFL	UFL	—	KFL
インサート軸受 INSERT BEARINGS	偏心カラータイプ ECCENTRIC COLOR TYPE	U	—	—	U+ER
	止ねじタイプ SET SCREW TYPE	K	SU	—	K

■軽量形ステンレス ベアリングユニット / LIGHT STAINLESS BEARING UNITS

		KMT	FYH	NTN	ASAHI
ピロー形ユニット PILLOW UNITS	偏心カラータイプ ECCENTRIC COLOR TYPE	SUP	—	—	MUP
	止ねじタイプ SET SCREW TYPE	SKP	USP-S6	—	—
ひしフランジ形ユニット RHOMBUS FLANGED UNITS	偏心カラータイプ ECCENTRIC COLOR TYPE	SUFL	—	—	MUFL
	止ねじタイプ SET SCREW TYPE	SKFL	USFL-S6	—	—
インサート軸受 INSERT BEARINGS	偏心カラータイプ ECCENTRIC COLOR TYPE	SU	—	—	MU+ER
	止ねじタイプ SET SCREW TYPE	SK	SU-S6	—	—

■オイルレスブッシュ(オイルレスベアリング) / OILLESS BUSH(OILLESS BEARING)

	KMT	オイルレス工業	大同メタル工業	三協オイルレス	テクノバース
オイルレスブッシュ(オイルレスベアリング) / OILLESS BUSH(OILLESS BEARING)	JDB	SPB	HA	SOB	MPB

常用するはめあい寸法公差

■常用する穴基準はめあい

基準穴	軸の公差域クラス																					
	すきまばめ					中間ばめ					しまりばめ											
H6						g5	h5	js5	k5	m5												
H7						f6	g6	h6	js6	k6	m6	n6	p6					r6	s6	t6	u6	x6
H8						f7	g7	h7	js7													
H9						f8	g8	h8														
H10	b9	c9	d9			d8	e8		h8													

■軸の寸法許容差

基準寸法の区分(mm)		軸の公差域クラス																
を超え	以下	b9	c9	d8	d9	e7	e8	e9	f6	f7	f8	g5	g6	h5	h6	h7	h8	h9
-	3	-140 -165	-60 -85	-20 -34	-20 -45	-14 -24	-14 -28	-14 -39	-6 -12	-6 -16	-6 -20	-2 -6	-2 -8	0 -4	0 -6	0 -10	0 -14	0 -25
3	6	-140 -170	-70 -100	-30 -48	-30 -60	-20 -32	-20 -38	-20 -50	-10 -18	-10 -22	-10 -28	-4 -9	-4 -12	0 -5	0 -8	0 -12	0 -18	0 -30
6	10	-150 -186	-80 -116	-40 -62	-40 -76	-25 -40	-25 -47	-25 -61	-13 -22	-13 -28	-13 -35	-5 -11	-5 -14	0 -6	0 -9	0 -15	0 -22	0 -36
10	14	-150 -193	-95 -138	-50 -77	-50 -93	-32 -50	-32 -59	-32 -75	-16 -27	-16 -34	-16 -43	-6 -14	-6 -17	0 -8	0 -11	0 -18	0 -27	0 -43
14	18	-160 -212	-110 -162	-65 -98	-65 -117	-40 -61	-40 -73	-40 -92	-20 -33	-20 -41	-20 -53	-7 -16	-7 -20	0 -9	0 -13	0 -21	0 -33	0 -52
30	40	-170 -232	-120 -182	-80 -119	-80 -142	-50 -75	-50 -89	-50 -112	-25 -41	-25 -50	-25 -64	-9 -20	-9 -25	0 -11	0 -16	0 -25	0 -39	0 -62
40	50	-180 -242	-130 -192	-119 -142	-142	-75 -89	-89	-112	-41	-50	-64	-20	-25	-11	-16	-25	-39	-62
50	65	-190 -264	-140 -214	-100 -146	-100 -174	-60 -90	-60 -106	-60 -134	-30 -49	-30 -60	-30 -76	-10 -23	-10 -29	0 -13	0 -19	0 -30	0 -46	0 -74
65	80	-200 -274	-150 -224	-146 -174	-174	-90 -106	-106	-134	-49	-60	-76	-23	-29	-13	-19	-30	-46	-74
80	100	-220 -307	-170 -257	-120 -174	-120 -207	-72 -107	-72 -126	-72 -159	-36 -58	-36 -71	-36 -90	-12 -27	-12 -34	0 -15	0 -22	0 -35	0 -54	0 -87
100	120	-240 -327	-180 -267	-174 -207	-207	-107 -126	-126	-159	-58	-71	-90	-27	-34	-15	-22	-35	-54	-87
120	140	-260 -360	-200 -300															
140	160	-280 -380	-210 -310	-145 -208	-145 -245	-85 -125	-85 -148	-85 -185	-43 -68	-43 -83	-43 -106	-14 -32	-14 -39	0 -18	0 -25	0 -40	0 -63	0 -100
160	180	-310 -410	-230 -330															
180	200	-340 -455	-240 -355															
200	225	-380 -495	-260 -375	-170 -242	-170 -285	-100 -146	-100 -172	-100 -215	-50 -79	-50 -96	-50 -122	-15 -35	-15 -44	0 -20	0 -29	0 -46	0 -72	0 -115
225	250	-420 -535	-280 -395															
250	280	-480 -610	-300 -430	-190 -271	-190 -320	-110 -162	-110 -191	-110 -240	-56 -88	-56 -108	-56 -137	-17 -40	-17 -49	0 -23	0 -32	0 -52	0 -81	0 -130
280	315	-540 -670	-330 -460															
315	355	-600 -740	-360 -500	-210 -299	-210 -350	-125 -182	-125 -214	-125 -265	-62 -98	-62 -117	-62 -151	-18 -43	-18 -54	0 -25	0 -36	0 -57	0 -89	0 -140
355	400	-680 -820	-400 -540															
400	450	-760 -915	-440 -595	-230 -327	-230 -385	-135 -198	-135 -232	-135 -290	-68 -108	-68 -131	-68 -165	-20 -47	-20 -60	0 -27	0 -40	0 -63	0 -97	0 -155
450	500	-840 -995	-480 -635															

単位/μm

基準寸法の区分(mm)		軸の公差域クラス														
を超え	以下	js5	js6	js7	k5	k6	m5	m6	n5	n6	p6	r6	s6	t6	u6	x6
-	3	±2	±3	±4	+4 0	+6 0	+6 +2	+8 +2	+8 +4	+10 +4	+12 +6	+16 +10	+20 +14	-	+24 +18	+26 +20
3	6	±2.5	±4	±6	+6 +1	+9 +1	+9 +4	+12 +4	+13 +8	+16 +8	+20 +12	+23 +15	+27 +19	-	+31 +23	+36 +28
6	10	±3	±4.5	±7.5	+7 +1	+10 +1	+12 +6	+15 +6	+16 +10	+19 +10	+24 +15	+28 +19	+32 +23	-	+37 +28	+43 +34
10	14	±4	±5.5	±9.5	+9 +1	+12 +1	+15 +7	+18 +7	+20 +12	+23 +12	+29 +18	+34 +23	+39 +28	-	+44 +33	+51 +40
14	18															+56 +45
18	24	±4.5	±6.5	±10.5	+11 +2	+15 +2	+17 +8	+21 +8	+24 +15	+28 +15	+35 +22	+41 +28	+48 +35	-	+54 +41	+67 +54
24	30															+77 +64
30	40	±5.5	±8	±12.5	+13 +2	+18 +2	+20 +9	+25 +9	+28 +17	+33 +17	+42 +26	+50 +34	+59 +43	-	+76 +60	+86 +70
40	50															+86 +70
50	65	±6.5	±9.5	±15	+15 +2	+21 +2	+24 +11	+30 +11	+33 +20	+39 +20	+51 +32	+60 +41	+72 +53	+85 +66	+106 +87	
65	80														+121 +102	
80	100	±7.5	±11	±17.5	+18 +3	+25 +3	+28 +13	+35 +13	+38 +23	+45 +23	+59 +37	+73 +51	+93 +71	+113 +91	+146 +124	
100	120														+166 +144	
120	140	±9	±12.5	±20	+21 +3	+28 +3	+33 +15	+40 +15	-	+52 +27	+68 +43	+88 +63	+117 +92	+147 +122	-	-
140	160															
160	180	±10	±14.5	±23	+24 +4	+33 +4	+37 +17	+46 +17	-	+60 +31	+79 +50	+106 +77	+151 +122	-	-	-
180	200															
200	225	±11.5	±16	±26	+27 +4	+36 +4	+43 +20	+52 +20	-	+66 +34	+88 +56	+126 +94	+130 +98	-	-	-
225	250															
250	280	±12.5	±18	±28.5	+29 +4	+40 +4	+46 +21	+57 +21	-	+73 +37	+98 +62	+144 +108	+150 +114	-	-	-
280	315															
315	355	±13.5	±20	±31.5	+32 +5	+45 +5	+50 +23	+63 +23	-	+80 +40	+108 +68	+166 +126	+172 +132	-	-	-
355	400															
400	450	±13.5	±20	±31.5	+32 +5	+45 +5	+50 +23	+63 +23	-	+80 +40	+108 +68	+166 +126	+172 +132	-	-	-
450	500															

はめあい方式の選択 (JIS B 0401-1:2016 より抜粋)

■JISで推奨する穴基準での、はめあい状態

穴基準	軸公差クラス																	
	すきまばめ						中間ばめ						しまりばめ					
H6						g5	h5	js5	k5	m5		n5	p5					
H7					f6	g6	h6	js6	k6	m6	n6		p6	r6	s6	t6	u6	x6
H8				e7	f7		h7	js7	k7	m7				s7			u7	
H9			d8	e8	f8		h8											
H10	b9	c9	d9	e9			h9											
H11	b11	c11	d10				h10											

■JISで推奨する軸基準での、はめあい状態

穴基準	軸公差クラス																	
	すきまばめ						中間ばめ						しまりばめ					
h5						G6	H6	JS6	K6	M6		N6	P6					
h6					F7	G7	H7	JS7	K7	M7	N7		P7	R7	S7	T7	U7	X7
h7				E8	F8		H8											
h8			D9	E9	F9		H9											
h9				E8	F8		H8											
			D9	E9	F9		H9											
	B11	C10	D10				H10											

※はめあいの為の最初の選択肢は、できるだけ色表示の公差クラスの中から選ぶのがよい。
 ※良好なはめあいは、穴基準はめあい方式の組合せによるか、または特別な用途の軸基準はめあい方式の組合せによって得られる。

※はめあいの状態

すきまばめ	中間ばめ	しまりばめ
<ul style="list-style-type: none"> ●ガタあり ●常にすきまが出来るはめあい ●組付け、取り外しが容易 	<ul style="list-style-type: none"> ●ガタ小、或いは無し(軽圧入) ●イメージ的には手で押し込める程度のはめあい ●実寸法により、すきまの場合としめしろができる場合がある ●しめしろの場合は選択組合せまたは圧入を行う ●荷重方向や不均一な荷重がある場合に適用 ●回転軸に揺動運転がある場合に適用 ●取付けや取り外しの考慮を必要とする場合に適用 	<ul style="list-style-type: none"> ●ガタ無し(強圧入) ●常にしめしろがあるはめあい ●組付けは圧入や焼きばめ等の方法による ●荷重方向や不均一な荷重がある場合に適用 ●回転軸に高頻度の揺動運転がある場合に適用

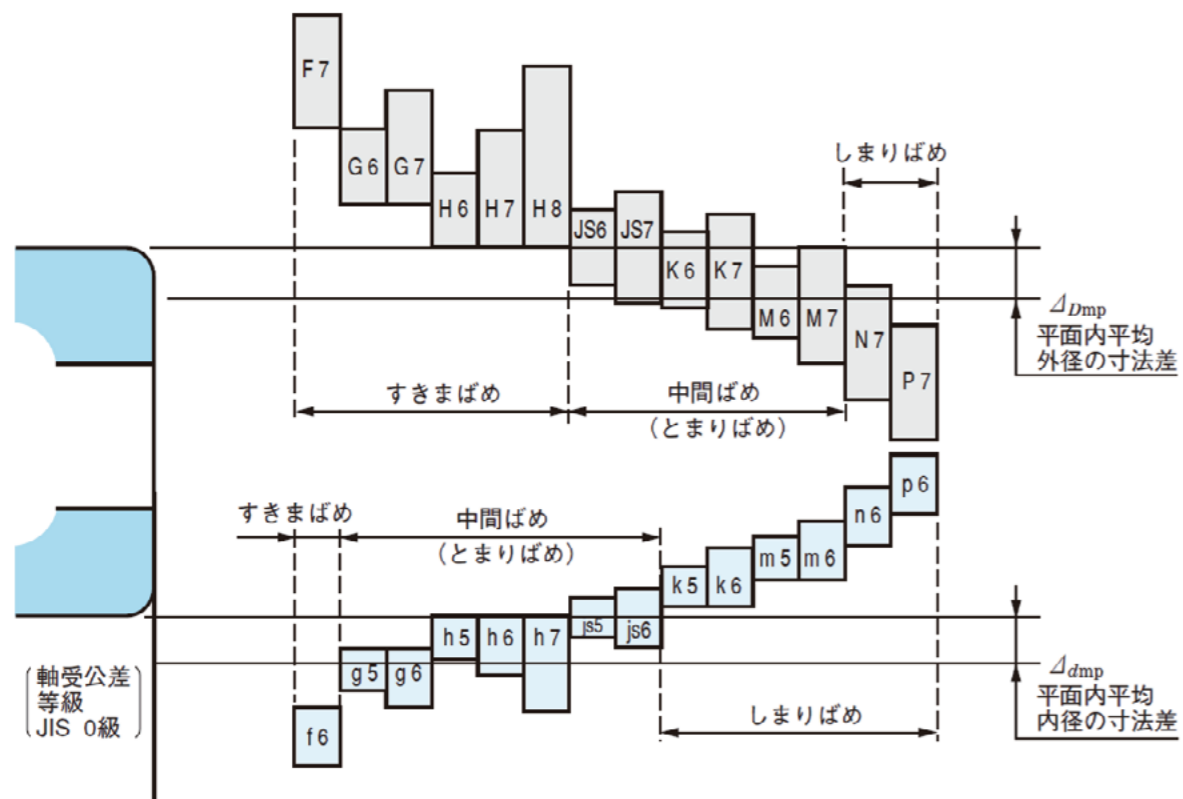

商品について

カタログ・ホームページ等に記載しております商品は、改良などの諸事情により予告なく仕様寸法等の変更や商品を廃止したりする場合がありますので、あらかじめご了承ください。

保証規定

カタログ・ホームページ等に記載されている商品の保証は、全て以下の保証規定に基づきます。KMTの商品をご購入又はご利用されている場合には、以下に示す保証規定をご承諾されているものとさせていただきます。また、当社の商品には保証書又は保証規定等は付属されておりませんが、以下の保証範囲が適用になることを併せてご了承ください。

保証範囲

ご購入いただいた商品につき、商品受領後の所定の検査では発見できなかった瑕疵(故障や不具合)が見つかった場合、当社の責めに帰すべき理由による瑕疵で、かつ納品後1年以内に書面にて当社に通知いただいたときに限り、当社の選択に従って、その商品の全部もしくは一部の交換、または商品の修理に応じさせていただきます。尚、以下に該当する場合には、この保証対象範囲から除外させていただきます。

1. 本来の使い方以外の使用による場合。
2. カタログ・ホームページ等で表記された条件以外の不適当な条件及び環境での取扱い、ならびに不注意な取扱いによる場合。
3. 天災・火災ならびに公害、その他当社販売商品以外の外部要因による故障及び損傷。
4. 出荷当時の化学・技術の水準では予想しえなかった事由による場合。
5. お客様ご自身の改造、修理による故障及び損傷。
6. 若干のすり傷や汚れやへこみなど、商品性能に影響のない軽微な外観上の問題は除きます。但し、商品性能に影響がなくても、特に著しいと認められる外観上の問題は保証の範囲とします。

当社商品を兵器、武器ならびにこれらの製造設備及び及び軍用用途や軍事工場などで一切使用しないでください。尚、当社商品に関連して発生した以下に記載された障害及び損害につきましても、当社は一切の責任を負わないものとします。

- ・当社が販売した商品の使用により、または商品が使用できなかったことによる間接的障害
- ・故意または過失、あるいは不可抗力による損害又は損失
- ・輸入規制の取扱いに起因する障害、損害及び損失

以上の保証規定につきましては、日本国内でのお取引及び使用を前提としております。海外でのご使用の場合、保証事項に関しては、上記日本国内での保証規定と同様ですが、下記の場合は該当しません。

- ・お客様の使用が海外での規格・規制・法律を満たしていないことが原因で故障や不具合となった場合は「商品本来の使い方以外の使用」を認定し、商品の保証範囲から除外させていただきます。

About Our Product

We may change the specification of our product in this catalog or homepage without any notification, please understand this and accept our sincere apology.

Guarantee Policy

The guarantee policy for products listed on this catalog and homepage is following the terms below. If you purchase or use a KMT product, you can use our guarantee policy. There is not a Guarantee Description inside when the products delivered. Please notice the guarantee terms following.

Scope of Guarantee

Upon receiving the provisions of the products from the Seller, the Buyer shall conduct acceptance inspections immediately. If a defect which cannot be immediately discovered by the Buyer's acceptance inspections and is attributable to the Seller is found, and the Buyer notifies the Seller to that effect within one(1) year after delivery of the products, the Seller shall, at its option, replace some or all of the defective products, or repair the defective products at no charge. The guarantee will not apply to the situations below.

1. Using the product in a way out of the Specifications.
2. Using the product in an environment out of the Specifications.
3. A damage from Natural disasters & fire or any other external causes.
4. A situation we are not capable to foresee by the time we deliver the products.
5. malfunction caused by remaking the product.
6. A flaw on the outward, no influence to the function. (Significant flaws can get the guarantee service).

Do not use our products on weapons or weapon factories. The damage and loss below that related to our products are out of the guarantee policy.

- ・A damage caused by a subject using our product or a subject using our product by mistake.
- ・A damage caused by a subject using our product on purpose or by mistake.
- ・A loss caused by the Import Restrictions.

All the things mentioned above are for the customers in Japan. The guarantee policy is same for the customers overseas except the situation below. We will take this situation as [Using the product in a way out of the Specifications] which is not included in the guarantee policy.